

PE1000+TM *Epoxy Injection Adhesive Anchoring System*

ADHESIVES

PRODUCT DESCRIPTION

The PE1000+ is a two-component, high strength adhesive anchoring system. The system includes injection adhesive in plastic cartridges, mixing nozzles, dispensing tools and hole cleaning equipment. The PE1000+ is designed for bonding threaded rod and reinforcing bar hardware into drilled holes in concrete base and solid masonry materials.

GENERAL APPLICATIONS AND USES

- Bonding threaded rod and reinforcing bar into hardened concrete and grouted CMU
- Evaluated for installation and use in dry and water-saturated concrete including water-filled holes
- Suitable to resist loads in cracked or uncracked concrete base materials for cases where anchor design theory and criteria applies
- Qualified for seismic and wind loading (see ESR-2583)
- Qualified for use in hammer-drill and diamond core drilled holes
- Can be installed in a wide range of base material temperatures

FEATURES AND BENEFITS

- + Designed for use with threaded rod and reinforcing bar hardware elements
- + Consistent performance in low and high strength concrete (2,500 to 8,500 psi)
- + Evaluated and recognized for freeze/thaw performance
- + Evaluated and recognized for long term and short term loading (see performance tables for applicable temperature ranges)
- + Evaluated and recognized for variable embedments (see installation specifications)
- + Cartridge design allows for multiple uses using extra mixing nozzles
- + Mixing nozzles proportion adhesive and provide simple delivery method into drilled holes
- + Easy dispensing reduces applicator fatigue

APPROVALS AND LISTINGS

International Code Council, Evaluation Service (ICC-ES) ESR-2583
 Code compliant with the 2009 IBC, 2009 IRC, 2006 IBC, 2006 IRC, 2003 IBC, 2003 IRC, and 1997 UBC
 Tested in accordance with AC308 for use in structural concrete according to ACI 318 Appendix D (Strength Design) and as amended by provisions of ICC-ES AC308 Annex A, Section 3.3 (www.icc-es.org)
 Evaluated and qualified by an accredited independent testing laboratory for recognition in cracked and uncracked concrete including seismic and wind loading
 Compliant with NSF/ANSI Standard 61 for drinking water system components – health effects; minimum requirements for materials in contact with potable water and water treatment
 Conforms to requirements of ASTM C 881, Types I, II, IV and V, Grade 3, Classes B & C (also meets type III except for elongation)
 Department of Transportation listings – see www.powers.com or contact transportation agency

GUIDE SPECIFICATIONS

CSI Divisions: 03151-Concrete Anchoring, 04081-Masonry Anchorage and 05090-Metal Fastenings.
 Adhesive anchoring system shall be PE1000+ as supplied by Powers Fasteners, Inc., Brewster, NY.
 Anchors shall be installed in accordance with published instructions and requirements of the Authority Having Jurisdiction.

SECTION CONTENTS	Page No.
General Information	1
Installation Specifications	2
Installation Instructions	3
Performance Data	6
Ordering Information	17



PE1000+ dual cartridge and mixing nozzle

PACKAGING

- Dual (side-by-side) Cartridge**
 13 fl. oz. (385 ml)
 20 fl. oz. (585ml)
 47 fl. oz. (1400ml)

STORAGE LIFE & CONDITIONS

Two years in a dry, dark environment with temperature ranging from 41°F to 95°F (5°C to 35°C)

ANCHOR SIZE RANGE (TYP.)

3/8" to 1-1/4" diameter threaded rod
 No. 3 to No.10 reinforcing bar (rebar)

SUITABLE BASE MATERIALS

Normal-weight concrete
 Grouted concrete masonry



This Product Available In



Powers Design Assist
 Real Time Anchor Design Software
www.powersdesignassist.com

INSTALLATION SPECIFICATIONS

Installation Specifications for Threaded Rod and Reinforcing Bar

Dimension/Property		Notation	Units	Nominal Anchor Size								
Threaded Rod		-	-	3/8"	1/2"	5/8"	3/4"	7/8"	1"	-	1-1/4"	-
Reinforcing Bar		-	-	#3	#4	#5	#6	#7	#8	#9	-	#10
Nominal anchor diameter		d	in. (mm)	0.375 (9.5)	0.500 (12.7)	0.625 (15.9)	0.750 (19.1)	0.875 (22.2)	1.000 (25.4)	1.125 (28.6)	1.250 (31.8)	1.250 (31.8)
Carbide drill bit nominal size		d _o [d _{bit}]	in.	7/16 ANSI	9/16 ANSI	11/16 or 3/4 ANSI	7/8 ANSI	1 ANSI	1-1/8 ANSI	1-3/8 ANSI	1-3/8 ANSI	1-1/2 ANSI
Diamond core bit nominal size		d _o [d _{bit}]	in.	-	5/8	3/4	7/8	1	1-1/8	-	-	-
Minimum embedment ¹		h _{ef,min}	in. (mm)	2-3/8 (61)	2-3/4 (70)	3-1/8 (79)	3-1/2 (89)	3-1/2 (89)	4 (102)	4-1/2 (114)	5 (127)	5 (127)
Maximum embedment ¹		h _{ef,max}	in. (mm)	4-1/2 (114)	6 (153)	7-1/2 (191)	9 (229)	10-1/2 (267)	12 (305)	13-1/2 (343)	15 (381)	15 (381)
Minimum concrete member thickness ¹		h _{min}	in. (mm)	$h_{ef} + 1-1/4$ ($h_{ef} + 30$)			$h_{ef} + 2d_o$					
Minimum spacing distance ¹		s _{min}	in. (mm)	1-7/8 (48)	2-1/2 (62)	3-1/8 (80)	3-3/4 (95)	4-3/8 (111)	5 (127)	5-5/8 (143)	6-1/4 (159)	6-1/4 (159)
Minimum edge distance ¹		c _{min}	in. (mm)	1-3/4 (45)					2-3/4 (70)			
Maximum torque	For c ≥ 5d	T _{inst}	ft.-lbf. (N-m)	15 (20)	33 (44)	60 (81)	105 (142)	125 (169)	165 (223)	-	280 (379)	-
	For c < 5d			7 (9)	15 (20)	27 (36)	47 (63)	56 (75)	74 (100)	-	126 (170)	-
Maximum torque ²	For c ≥ 5d	T _{inst}	ft.-lbf. (N-m)	10 (13)	25 (33)	50 (67)	90 (122)	125 (169)	165 (223)	-	280 (379)	-
	For c < 5d			5 (6)	11 (14)	22 (29)	40 (54)	56 (75)	74 (100)	-	126 (170)	-
Effective cross sectional area of threaded rod		A _{se}	in. ² (mm ²)	0.078 (50)	0.142 (92)	0.226 (146)	0.335 (216)	0.462 (298)	0.606 (391)	-	0.969 (625)	-
Effective cross sectional area of reinforcing bar		A _{se}	in. ² (mm ²)	0.110 (71)	0.200 (129)	0.310 (200)	0.440 (284)	0.600 (387)	0.790 (510)	1.000 (645)	-	1.270 (819)

1. For use with the design provisions of ACI 318 Appendix D and ICC-ES AC308 Appendix A, Section 3.3 and ESR-2583.

2. Applies to ASTM A36/F 1554 Grade 36 threaded rods.

Detail of Steel Hardware Elements used with Injection Adhesive System

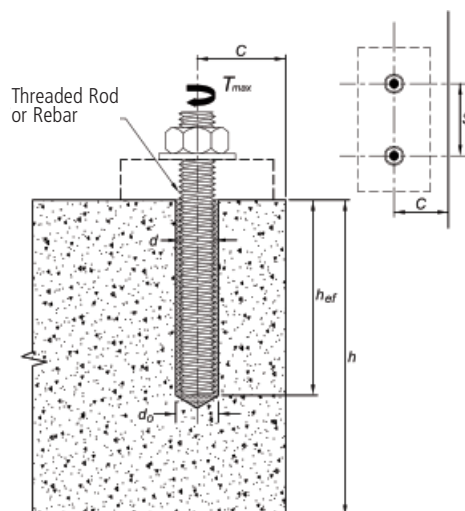

Steel Description (General)	Steel Specification (ASTM)	Nominal Anchor Size (inch)	Minimum Yield Strength f _y (ksi)	Minimum Ultimate Strength f _u (ksi)
Carbon Rod	A 36 or F 1554, Grade 36	3/8 through 1-1/4	36.0	58.0
	F 1554 Grade 55		55.0	75.0
	A 193, Grade B7 or F 1554, Grade 105		105.0	120.0
Stainless Rod (Alloy 304 / 316)	F 593 Condition CW	3/8 through 5/8	65.0	100.0
		3/4 through 1-1/4	45.0	85.0
Grade 60 Reinforcing Bar	A 615, or A 767, A 996	3/8 through 1-1/4 (#3 through #10)	60.0	90.0
	A 706		60.0	80.0
Grade 40 Reinforcing Bar	A 615	3/8 through 3/4 (#3 through #6)	40.0	60.0

ADHESIVES

INSTALLATION INSTRUCTIONS (SOLID BASE MATERIALS)

HAMMER DRILLING

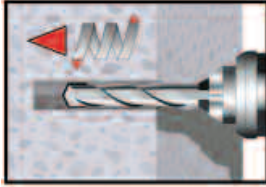

1 - Drill a hole into the base material with a rotary hammer drill tool to the size and embedment required by the selected anchor (*reference installation specifications for threaded rod and reinforcing bar*). The tolerances of the carbide drill bit should meet the requirements of ANSI Standard B212.15.

Precaution: Wear suitable eye and skin protection. Avoid inhalation of dusts during drilling and/or removal.

Note! After drilling and prior to hole cleaning, all standing water in the drilled bore hole must be removed if present (e.g. vacuum, compressed air, etc.)

HOLE CLEANING (HAMMER DRILLED HOLES) → BLOW 4x, BRUSH 4x, BLOW 4x

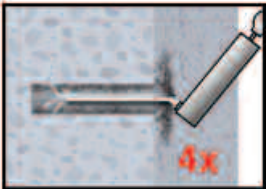

2a - Starting from the bottom or back of the anchor hole, blow the hole clean using a compressed air nozzle (min. 90 psi) or a hand pump (supplied by Powers Fasteners) a minimum of *four* times (4x).

- Use a compressed air nozzle (min. 90 psi) or a hand pump (min. volume 25 fl. oz.) for anchor rod 3/8" to 3/4" diameter or reinforcing bar (rebar) sizes #3 to #6.

- Use a compressed air nozzle (min. 90 psi) for anchor rod 7/8" to 1-1/4" diameter and rebar sizes #7 to #10. A hand pump shall not be used with these anchor sizes.

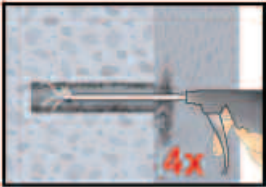

2b - Determine wire brush diameter (*reference hole cleaning equipment selection table*) and attach the brush with adaptor to a rotary drill tool or battery screwgun. Brush the hole with the selected wire brush a minimum of *four* times (4x). A brush extension (supplied by Powers Fasteners, Cat. #08282) should be used for holes drilled deeper than the listed brush length.

The wire brush diameter should be checked periodically during use. The brush must be replaced if it becomes worn (less than D_{min} , *reference hole cleaning equipment selection table*) or does not come into contact with the sides of the drilled hole.

2c - Finally, blow the hole clean again a minimum of *four* times (4x).

- Use a compressed air nozzle (min. 90 psi) or a hand pump (min. volume 25 fl. oz.) for anchor rod 3/8" to 3/4" diameter or reinforcing bar (rebar) sizes #3 to #6.

- Use a compressed air nozzle (min. 90 psi) for anchor rod 7/8" to 1-1/4" diameter and rebar sizes #7 to #10. A hand pump shall not be used with these anchor sizes.

When finished the hole should be clean and free of dust, debris, ice, grease, oil or other foreign material.

→ Next go to Step 3.

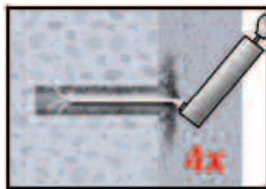

(Continued on next page)

INSTALLATION INSTRUCTIONS (SOLID BASE MATERIALS)

CORE DRILLING

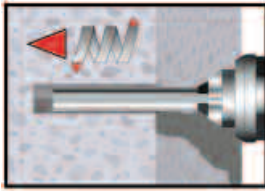

1 - Drill a hole into the base material with a rotary hammer drill tool to the size and embedment required by the selected anchor (*reference installation specifications for threaded rod and reinforcing bar*). The tolerances of the carbide drill bit should meet the requirements of ANSI Standard B212.15.

Drill a hole into the base material with core drill to the size and embedment required by the selected steel hardware element (see Table III).

Precaution: Wear suitable eye and skin protection. Avoid inhalation of dusts during drilling and/or removal.

Precaution: Wear suitable eye and skin protection. Avoid inhalation of dusts during drilling and/or removal.

Note! After drilling and prior to hole cleaning, all standing water in the drilled bore hole must be removed if present (e.g. vacuum, compressed air, etc.)

HOLE CLEANING (CORE DRILLED HOLES) → RINSE, BRUSH 2x, RINSE, BLOW 2x, BRUSH 2x, BLOW 2x

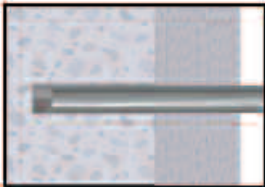

RINSE

2a - Starting from the bottom or back of the drilled anchor hole, rinse/flush the hole clean with water (water line pressure) until clear water comes out.

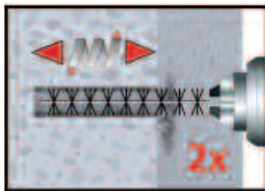

BRUSH 2x

2b - Determine brush diameter (see Table I) for the drilled hole and attach the brush with adaptor to a rotary drill tool or battery screw gun. Brush the hole with the selected wire brush a minimum of two times (**2x**).

A brush extension (supplied by Powers Fasteners) must be used for holes drilled deeper than the listed brush length. The wire brush diameter must also be checked periodically during use ($\varnothing_{brush} > D_{min}$, see Table I). The brush should resist insertion into the drilled hole, if not the brush is too small and must be replaced with the proper brush diameter.

REPEAT RINSING

2c - **Repeat Step 2a** again by rinse/flushing the hole clean with water.

Following this remove all standing water completely (e.g. vacuum, compressed air, etc.) prior to further cleaning. To attain a dried borehole a Powers compressed air nozzle is recommended.



BLOW 2x

2d - Starting from the bottom or back of the drilled anchor hole, blow the hole clean (free of). Use a compressed air nozzle (min. 90 psi) for all sizes of anchor rod and reinforcing bar (rebar).

REPEAT BRUSHING 2x

2e - **Repeat Step 2b** again by brushing the hole with a wire brush a minimum of two times (**2x**).

REPEAT BLOWING 2x

2f - **Repeat Step 2d** again by blowing the hole clean a minimum of two times (**2x**).

When finished the hole should be clean and free of dust, debris, ice, grease, oil or other foreign material.

→ **Next go to Step 3.**

(Continued on next page)

INSTALLATION INSTRUCTIONS (SOLID BASE MATERIALS)

PREPARING

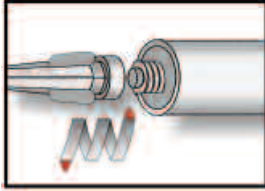

3- Check adhesive expiration date on cartridge label. Do not use expired product. Review Material Safety Data Sheet (MSDS) before use. Cartridge temperature must be between 41°F - 104°F (5°C - 40°C) when in use. Consideration should be given to the reduced gel time of the adhesive in warm temperatures.

Attach a supplied mixing nozzle to the cartridge. Do not modify the mixer in any way and make sure the mixing element is inside the nozzle. Load the cartridge into the correct dispensing tool. A new mixing nozzle must be used for every working interruption longer than the published working times (*reference gel time and curing time table*) as well as for new cartridges.

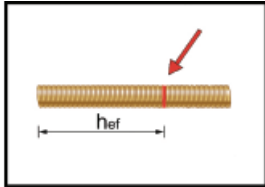

4- Prior to inserting the anchor rod or rebar into the filled bore hole, the position of the embedment depth has to be marked on the anchor. Verify anchor element is straight and free of surface damage.

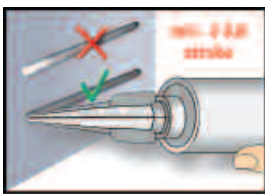

5- For new cartridges and nozzles: prior to dispensing into the anchor hole, squeeze out separately a minimum three full strokes of the mixed adhesive. Discard non-uniform adhesive until the mixed adhesive shows a consistent **red** color.

Review and note the published working and cure times (*reference gel time and curing time table*) prior to injection of the mixed adhesive into the cleaned anchor hole.

INSTALLATION

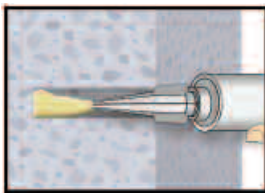

With Piston Plug

6- Fill the cleaned hole approximately two-thirds full with mixed adhesive starting from the bottom or back of the anchor hole. Slowly withdraw the mixing nozzle as the hole fills to avoid creating air pockets or voids. For embedment depth greater than 7-1/2" an extension nozzle (3/8" dia.) must be used with the mixing nozzle.

Piston plugs (see Adhesive Piston Plug Table) must be used with and attached to mixing nozzle and extension tube for horizontal and overhead installations with anchor rod from 3/4" to 1-1/4" diameter and rebar sizes #6 to #10. Insert piston plug to the back of the drilled hole and inject as described in the method above. During installation the piston plug will be naturally extruded from the drilled hole by the adhesive pressure.

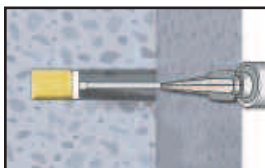

Attention! Do not install anchors overhead without proper training and installation hardware provided by Powers Fasteners. Contact Powers for details prior to use.

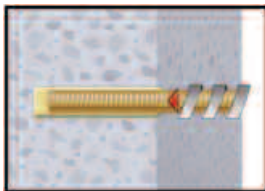

7- The anchor should be free of dirt, grease, oil or other foreign material. Push clean threaded rod or reinforcing bar into the anchor hole while turning slightly to ensure positive distribution of the adhesive until the embedment depth is reached. Air pockets are present when the threaded rod or rebar springs or air pockets burst during installation. In case of air pockets: remove rod or rebar, let the adhesive harden, re-drill the hole and repeat the complete installation.

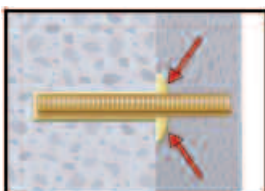

8- Be sure that the anchor is fully seated at the bottom of the hole and that some adhesive has flowed from the hole and all around the top of the anchor. If there is not enough adhesive in the hole, the installation must be repeated. For overhead applications the anchor must be secured from moving/falling during the cure time (e.g. wedges). Minor adjustments to the anchor may be performed during the gel time but the anchor shall not be moved after final placement and during cure.

(Continued on next page)

INSTALLATION INSTRUCTIONS (SOLID BASE MATERILAS)

CURING AND FIXTURE

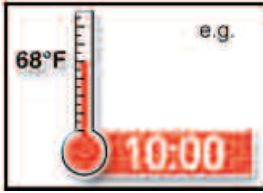

9- Allow the adhesive anchor to cure to the specified full curing time prior to applying any load (*reference gel time and curing time table*).

Do not disturb, torque or load the anchor until it is fully cured.

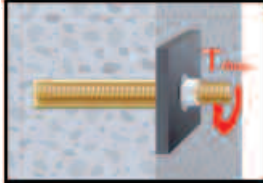

10- After full curing of the adhesive anchor, a fixture can be installed to the anchor and tightened up to the maximum torque (*reference gel time and curing time table*) by using a calibrated torque wrench.

Take care not to exceed the maximum torque for the selected anchor.

REFERENCE TABLES FOR INSTALLATION

Gel (working) Time and Curing Table			
Temperature of base material		Gel (working) time	Full curing time
°F	°C		
41	5	180 minutes	50 hours
50	10	120 minutes	24 hours
68	20	30 minutes	10 hours
86	30	20 minutes	6 hours
104	40	20 minutes	4 hours

Hole Cleaning Equipment Selection Table for PE1000+							
Threaded rod diameter (inch)	Rebar size (no.)	ANSI drill/Core bit diameter (inch)	Min. brush diameter, D _{min} (inches)	Brush length, L (inches)	Steel wire brush (Cat. #)	Blowout tool	Number of cleaning actions
3/8	#3	7/16	0.475	6-3/4	08284	Hand-pump cat# 08280 or compressed air nozzle (min. 90 psi)	4x blowing 4x brushing 4x blowing
1/2	#4	9/16	0.600	6-3/4	08285		
5/8	#5	11/16	0.735	7-7/8	08286		
		3/4	0.790	7-7/8	08278		
3/4	#6	7/8	0.920	7-7/8	08287	Compressed air nozzle only (min. 90 psi)	
7/8	#7	1	1.045	11-7/8	08288		
1	#8	1-1/8	1.175	11-7/8	08289		
1-1/4	#9	1-3/8	1.425	11-7/8	08290		
-	#10	1-1/2	1.550	11-7/8	08291		

1. An SDS-plus adaptor (Cat. #08283) or Jacobs chuck style adaptor (Cat. #08296) is required to attach a steel wire brush to the drill tool.
2. For installations with 5/8 threaded rod and #5 rebar size, the preferred ANSI drill bit diameter is 3/4-inch. If an 11/16-inch ANSI drill bit is used the user must check before injecting the adhesive to verify that the steel anchor element can be inserted into the cleaned bore hole without resistance.

Adhesive Piston Plugs					
Threaded rod diameter (inch)	Rebar size (no.)	ANSI drill/core bit diameter (inch)	Plug Size (inch)	Plastic Plug (Cat. #)	Horizontal and overhead installations
3/4	#6	7/8	7/8	08300	
7/8	#7	1	1	08301	
1	#8	1-1/8	1-1/8	08303	
1-1/4	#9	1-3/8	1-3/8	08305	
-	#10	1-1/2	1-1/2	08309	

A plastic extension tube (3/8" dia., Cat# 08281) must be used with piston plugs.

PERFORMANCE DATA

Tension Design Information for Threaded Rod and Reinforcing Bar in Normal-Weight Concrete
(For use with load combinations taken from ACI 318 Section 9.2)^{1,2}

ADHESIVES

Design Characteristic	Notation	Units	Nominal Anchor Size								
			3/8"	1/2"	5/8"	3/4"	7/8"	1"	-	1-1/4"	
			#3	#4	#5	#6	#7	#8	#9	#10	
Minimum embedment	$h_{ef,min}$	in. (mm)	2-3/8 (60)	2-3/4 (70)	3-1/8 (79)	3-1/4 (89)	3-1/4 (89)	4 (102)	4-1/2 (119)	5 (127)	
STEEL STRENGTH IN TENSION³											
Effective cross sectional area of threaded rod	A_{se}	in ² (mm ²)	0.078 (50)	0.142 (92)	0.226 (146)	0.335 (216)	0.462 (289)	0.606 (391)	-	0.969 (625)	
Steel strength in tension For Carbon Rod	ASTM A 36 or F 1554 Grade 36	N_{sa}^{10}	lb (kN)	4,495 (20.0)	8,230 (36.6)	13,110 (58.3)	19,400 (86.3)	26,780 (119.1)	35,130 (156.3)	-	56,210 (250.0)
	ASTM F 1554 Grade 55			5,810 (25.9)	10,640 (47.3)	16,950 (75.4)	25,085 (111.6)	34,625 (154.0)	45,425 (202.0)	-	72,680 (323.3)
	ASTM A 193, Grade B7 or F 1554, Grade 105			9,685 (43.1)	17,735 (78.9)	28,250 (125.7)	41,810 (186.0)	57,710 (256.7)	75,710 (336.8)	-	121,135 (538.8)
	Strength reduction factor for tension ⁴	ϕ	-	0.75							
Steel strength in tension Stainless Steel Rod	Alloy 304 / 316 ASTM F 593, Condition CW	N_{sa}^{10}	lb (kN)	7,750 (34.5)	14,190 (63.1)	22,600 (100.5)	28,430 (126.5)	39,245 (174.6)	51,485 (229.0)	-	82,370 (366.4)
	Strength reduction factor for tension ⁴	ϕ	-	0.65							
Effective cross sectional area of reinforcing bar	A_{se}	in ² (mm ²)	0.110 (71)	0.200 (129)	0.310 (200)	0.440 (284)	0.600 (387)	0.790 (510)	1.000 (645)	1.270 (819)	
Steel strength in tension For ASTM A 615 Reinforcing Bars	ASTM A 615, Grade 60	N_{sa}^{10}	lb (kN)	9,900 (44.0)	18,000 (80.1)	27,900 (124.1)	39,600 (176.1)	54,000 (240.2)	71,100 (316.3)	90,000 (400.3)	114,300 (508.4)
	ASTM A 615, Grade 40	N_{sa}^{10}	lb (kN)	6,600 (29.4)	12,000 (53.4)	18,600 (82.7)	26,400 (117.4)	-	-	-	-
	Strength reduction factor for tension ⁴	ϕ	-	0.65							
Steel strength in tension For ASTM A 706 Reinforcing Bars	ASTM A 706, Grade 60	N_{sa}^{10}	lb (kN)	8,800 (39.1)	16,000 (71.2)	24,800 (110.3)	35,200 (156.6)	48,000 (213.5)	63,200 (281.1)	80,000 (355.9)	101,600 (452.0)
	Strength reduction factor for tension ⁴	ϕ	-	0.75							
CONCRETE BREAKOUT STRENGTH IN TENSION											
Effectiveness factor for uncracked concrete	$k_{c,uncr}$	-								24	
Effectiveness factor for cracked concrete	$k_{c,cr}$	-	Not Applicable							17	
Modification factor for cracked and uncracked concrete ⁵	$\psi_{c,N}^{10}$	-	For all design cases use $\psi_{c,N} = 1.0$								
Critical edge distance	c_{ac}	in. (mm)	2 h_{ef} for $h / h_{ef} \geq 2$; $h_{ef} [4 - (h / h_{ef})]$ for $1.3 h_{ef} < h < 2h_{ef}$; 2.7 h_{ef} for $h / h_{ef} \leq 1.3$								
Reduction factor for concrete breakout strength	ϕ	-	0.65 (Condition B)								
BOND STRENGTH IN TENSION FOR INSTALLATIONS IN HOLES DRILLED WITH A HAMMER DRILL AND CARBIDE BIT											
Temperature Range A ⁵	Characteristic bond strength, cracked concrete (2,500 psi)	$\tau_{k,cr}$	psi (N/mm ²)	Not Applicable	960 (606)	788 (5.4)	733 (5.1)	691 (4.8)	691 (4.8)	691 (4.8)	691 (4.8)
	Characteristic bond strength, uncracked concrete (2,500 psi)	$\tau_{k,uncr}$	psi (N/mm ²)	2,110 (14.5)	1,984 (13.7)	1,891 (13.1)	1,818 (12.6)	1,759 (12.2)	1,709 (11.7)	1,667 (11.5)	1,629 (11.2)
Temperature Range B ^{5,6,7}	Characteristic bond strength, cracked concrete (2,500 psi)	$\tau_{k,cr}$	psi (N/mm ²)	Not Applicable	527 (3.6)	434 (3.0)	404 (2.8)	380 (2.6)	380 (2.6)	380 (2.6)	380 (2.6)
	Characteristic bond strength, uncracked concrete (2,500 psi)	$\tau_{k,uncr}$	psi (N/mm ²)	1,160 (7.9)	1,091 (7.5)	1,039 (7.2)	1,000 (6.9)	967 (6.7)	939 (6.5)	917 (6.3)	896 (6.2)
Permissible Installation Conditions	Dry concrete	ϕ_d	-	0.65							
	Water-saturated concrete	ϕ_{ws}	-	0.55			0.45				
		K_{ws}	-	1.0						0.99	0.97
	Water-filled hole (flooded)	ϕ_{wf}	-	0.45							
K_{wf}		-	0.89	0.80	0.73	0.68	0.63	0.60	0.57	0.55	

1. Bond strength values correspond to concrete compressive strength $f'c = 2,500$ psi. For concrete compressive strength, $f'c$ between 2,500 and 8,000 psi, the tabulated characteristic bond strength may be increased by a factor of $(f'c / 2,500)^{0.12}$ [For SI: $f'd(17.2)^{0.12}$]. See ESR-2583 Section 4.1.8.
 2. Temperature Range A: Maximum short-term temperature = 104°F (40°C), maximum long-term temperature = 75°F (24°C).
 3. Temperature Range B: Maximum short-term temperature = 140°F (60°C), maximum long-term temperature = 110°F (43°C). The maximum short term temperature may be increased to 162°F (72°C) for Temperature Range B provided characteristic bond strengths are reduced 10 percent.
 4. The data in this table is intended to be used together with the design provisions of ACI 318 Appendix D and ICC-ES AC308 Annex A, Section 3.3 and ESR-2583.
 5. Installation must comply with published instructions and details. Periodic inspection must be performed where required by code or the Authority Having Jurisdiction (AHJ).
 6. For utility classification of steel anchor elements see ESR-2583.
 7. The tabulated value of ϕ applies when the load combinations of Section 1605.2.1 of the IBC, Section 1612.2.1 of the UBC, or ACI 318 Section 9.2 are used in accordance with ACI 318 D.4.4. If the load combinations of ACI 318 Appendix C or Section 1909.2 of the UBC are used, the appropriate value of ϕ must be determined in accordance with ACI 318 D.4.5.
 8. Long term concrete temperatures are roughly constant over significant periods of time. Short-term elevated temperatures are those that occur over brief intervals, e.g. as a result of diurnal cycling.
 9. For load combinations consisting of short term loads only such as wind, bond strength may be increased by 15% for Temperature Range A and 75% for Temperature Range B.
 10. Maximum short term temperature for Temperature Range B may be increased to 162°F (72°C) provided the tabulated characteristic bond strengths are reduced by 10%.

PERFORMANCE DATA

**Tension Design Information for Threaded Rod and Reinforcing Bar in Normal-Weight Concrete
(For use with load combinations taken from ACI 318 Section 9.2)^{1,2}**

Design Characteristic	Notation	Units	Nominal Anchor Size								
			3/8"	1/2"	5/8"	3/4"	7/8"	1"	-	1-1/4"	
			#3	#4	#5	#6	#7	#8	#9	#10	
Minimum embedment	$h_{ef,min}$	in. (mm)	2-3/8 (60)	2-3/4 (70)	3-1/8 (79)	3-1/4 (89)	3-1/4 (89)	4 (102)	4-1/2 (119)	5 (127)	
BOND STRENGTH IN TENSION FOR INSTALLATIONS IN HOLES DRILLED WITH A CORE DRILL AND DIAMOND CORE BIT¹											
Temperature Range A ^{2,4,5}	Characteristic bond strength, uncracked concrete	$\tau_{k,uncr}$	psi (N/mm ²)	-	1,419 (9.8)	1,351 (9.3)	1,298 (9.0)	1,257 (8.7)	1,221 (8.4)	-	-
Temperature Range B ^{2,3,4,5}	Characteristic bond strength, uncracked concrete	$\tau_{k,uncr}$	psi (N/mm ²)	-	1,074 (7.4)	1,023 (7.1)	983 (6.8)	951 (6.6)	924 (6.4)	-	-
Permissible Installation Conditions ⁶	Dry concrete	ϕ_d	-	-	0.55	0.45			-	-	
	Water-saturated concrete	ϕ_{ws}	-	-	0.55	0.45			-	-	
		K_{ws}	-	-	1.0			-	-		
	Water-filled hole (flooded)	ϕ_{ws}	-	-	0.45			-	-		
		$\tau_{K_{wf}}$	-	-	0.94	0.95		0.96	-	-	

ADHESIVES

- Bond strength values correspond to concrete compressive strength $f'_c = 2,500$ psi. For concrete compressive strength, f'_c between 2,500 and 8,000 psi, the tabulated characteristic bond strength may be increased by a factor of $(f'_c / 2,500)^{0.12}$ [For SI: $f'_c / 17.2)^{0.12}$]. See ESR-2583 Section 4.1.8.
- Temperature Range A: Maximum short-term temperature = 104°F (40°C), maximum long-term temperature = 75°F (24°C).
- Bond strength values correspond to concrete compressive strength $f'_c = 2,500$ psi. For concrete compressive strength, f'_c between 2,500 and 8,000 psi, the tabulated characteristic bond strength may be increased by a factor of $(f'_c / 2,500)^{0.12}$ [For SI: $f'_c / 17.2)^{0.12}$]. See ESR-2583 Section 4.1.8.
- Temperature Range A: Maximum short-term temperature = 104°F (40°C), maximum long-term temperature = 75°F (24°C).
- Temperature Range B: Maximum short-term temperature = 140°F (60°C), maximum long-term temperature = 110°F (43°C). The maximum short term temperature may be increased to 162°F (72°C) for Temperature Range B provided characteristic bond strengths are reduced 10 percent.
- Short term elevated concrete temperatures are those that occur over brief intervals, e.g. as a results of diurnal cycling. Long-term concrete temperatures are roughly constant over significant periods of time.
- Characteristic bond strengths are for sustained loads including dead and live loads. For load combinations consisting of short-term loads only such as wind or seismic, bond strengths may be increased by 50 percent for Temperature Range A and 70 percent for Temperature Range B.
- Permissible installation conditions include dry concrete, water-saturated concrete and water-filled holes. Water-filled holes include applications in dry or water-saturated concrete where the drilled holes contain standing water at the time of anchor installation. See published installation instructions.

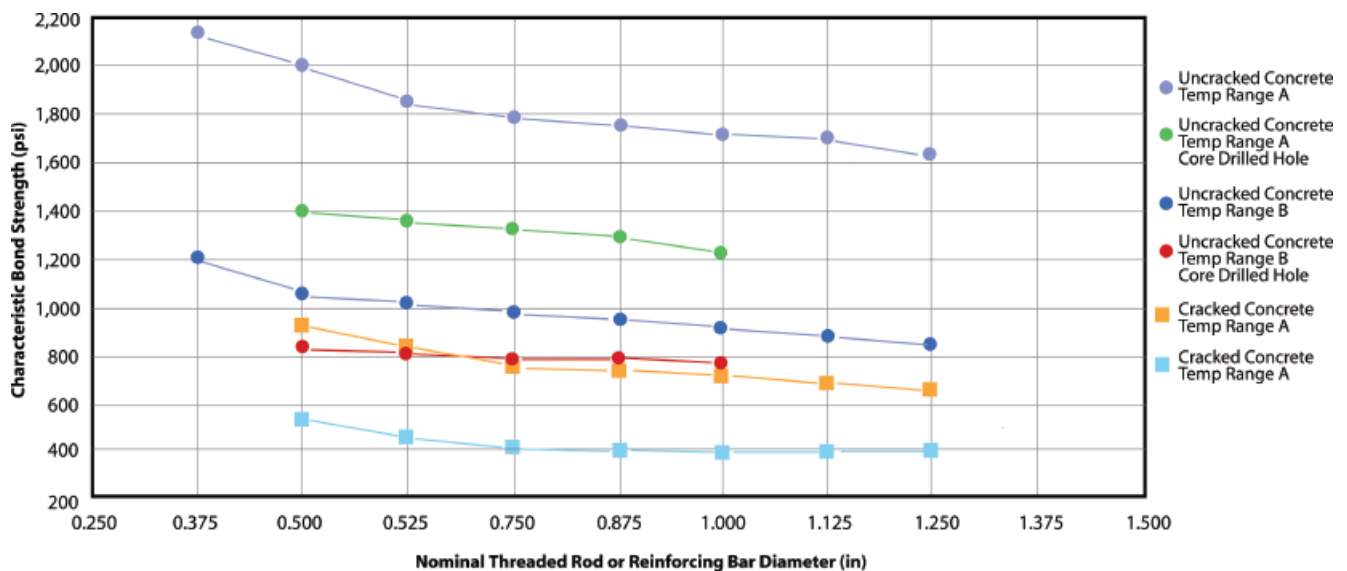

PERFORMANCE DATA

**Shear Design Information for Threaded Rod and Reinforcing Bar in Normal-Weight Concrete
(For use with load combinations taken from ACI 318 Section 9.2)^{1,2}**

ADHESIVES

Design Characteristic	Notation	Units	Nominal Anchor Size								
			3/8"	1/2"	5/8"	3/4"	7/8"	1"	-	1-1/4"	
			#3	#4	#5	#6	#7	#8	#9	#10	
Minimum embedment	$h_{ef,min}$	in. (mm)	2-3/8 (60)	2-3/4 (70)	3-1/8 (79)	3-1/4 (89)	3-1/4 (89)	4 (102)	4-1/2 (119)	5 (127)	
STEEL STRENGTH IN SHEAR³											
Steel strength in tension For Carbon Steel Rod	ASTM A 36 or F 1554 Grade 36	V_{sa}^{10}	lb (kN)	2,245 (10.0)	4,940 (22.0)	7,860 (35.0)	11,640 (51.8)	16,070 (71.4)	21,080 (93.8)	-	33,725 (150.0)
	ASTM F 1554 Grade 55			2,905 (12.9)	6,385 (28.4)	10,170 (45.2)	15,050 (67.0)	20,775 (92.4)	27,255 (121.2)	-	43,610 (194.0)
	ASTM A 193, Grade B7 or F 1554, Grade 105			4,845 (21.5)	10,640 (47.3)	16,950 (75.4)	25,085 (111.6)	34,625 (154.0)	45,425 (202.1)	-	72,680 (323.3)
	Reduction factor for seismic shear	V_{seis}	-	Not Applicable	0.85			0.80	-	0.80	
	Strength reduction factor for shear ⁴	ϕ	-	0.65							
Steel strength in tension Stainless Steel Rod	Alloy 304 / 316 ASTM F 593, Condition CW	V_{sa}^{10}	lb (kN)	3,875 (17.2)	8,515 (37.9)	13,560 (60.3)	17,060 (75.9)	23,545 (104.7)	30,890 (137.4)	-	49,425 (219.8)
	Reduction factor for seismic shear	V_{seis}	-	Not Applicable	0.85			0.80	-	0.80	
	Strength reduction factor for shear ⁴	ϕ	-	0.60							
Steel strength in tension For ASTM A 615/A 767 Reinforcing Bars	ASTM A 615, Grade 60	V_{sa}^{10}	lb (kN)	5,940 (26.4)	10,800 (48.0)	16,740 (74.5)	23,760 (105.7)	32,400 (144.1)	42,660 (189.8)	54,000 (240.2)	68,580 (305.0)
	ASTM A 615, Grade 40	V_{sa}^{10}	lb (kN)	3,960 (17.6)	7,200 (32.0)	11,160 (49.6)	15,840 (70.5)	-	-	-	-
	Reduction factor for seismic shear	V_{seis}	-	Not Applicable	0.70			0.75			
	Strength reduction factor for shear ⁴	ϕ	-	0.60							
Steel strength in tension For ASTM A 706 Reinforcing Bars	ASTM A 706, Grade 60	V_{sa}^{10}	lb (kN)	5,280 (23.5)	9,600 (42.7)	14,880 (66.2)	21,120 (94.0)	28,800 (128.1)	37,920 (168.7)	48,000 (213.5)	60,960 (271.2)
	Reduction factor for seismic shear	V_{seis}	-	Not Applicable	0.70			0.75			
	Strength reduction factor for shear ⁴	ϕ	-	0.65							
CONCRETE BREAKOUT STRENGTH IN SHEAR⁶											
Load bearing length of anchor	e_e^9	in. (mm)	h_{ef} or $8d_o$, whichever is less								
Reduction factor for concrete breakout strength ³	ϕ	-	0.70 (Condition B)								
CONCRETE PRYOUT STRENGTH IN SHEAR⁶											
Coefficient for pryout strength (1.0 for $h_{ef} < 2.5$ in., 2.0 for $h_{ef} \geq 2.5$ in.)	k_{cp}	-	1.0 for $h_{ef} < 2.5$ in., 2.0 for $h_{ef} \geq 2.5$ in.								
Reduction factor for pryout strength ³	ϕ	-	0.70 (Condition B)								

- The data in this table is intended to be used together with the design provision of ACI 318 Appendix D and ICC-ES AC308 Annex A, Section 3.3 and ESR-2583.
- Installation must comply with published instruction and details. Periodic special inspection must be performed where required by code or the Authority Having Jurisdiction (AHJ).
- For ductility classification of steel anchor elements see ESR-2583.
- The tabulated value of ϕ applies when the load combinations of Section 1605.2.1 of the IBC, Section 1612.2.1 of the UBC, or ACI 318 Section 9.2 are used in accordance with ACI 318 D.4.4. If the load combinations of ACI 318 Appendix C or Section 1909.2 of the UBC are used, the appropriate value of ϕ must be determined in accordance with ACI 318 D.4.5.

BOND STRENGTH DETERMINATION				
Concrete State	Hole Drilling Method	Installation Condition	Bond Strength	Strength Reduction Factor
Cracked	Hammer-drill	Dry concrete	$\tau_{k,cr}$	ϕ_d
		Water-saturated concrete	$\tau_{k,cr} \cdot K_{ws}$	ϕ_{ws}
		Water-filled hole (flooded)	$\tau_{k,cr} \cdot K_{wf}$	ϕ_{wf}
Uncracked	Hammer-drill	Dry concrete	$\tau_{k,uncr}$	ϕ_d
		Water-saturated concrete	$\tau_{k,uncr} \cdot K_{ws}$	ϕ_{ws}
		Water-filled hole (flooded)	$\tau_{k,uncr} \cdot K_{wf}$	ϕ_{wf}
Uncracked	Core Drill	Dry concrete	$\tau_{k,uncr}$	ϕ_d
		Water-saturated concrete	$\tau_{k,uncr} \cdot K_{ws}$	ϕ_{ws}
		Water-filled hole (flooded)	$\tau_{k,uncr} \cdot K_{wf}$	ϕ_{wf}

For concrete compressive strength between 2,500 psi and 8,000 psi, the tabulated characteristic bond strength for cracked concrete $\tau_{k,cr}$ or uncracked concrete $\tau_{k,uncr}$ may be increased by a factor of $(f'c / 2,500)^{0.12}$.

Factored Design Strength (ϕN_n and ϕV_n) in Accordance with ACI 318 Appendix D and ICC-ES AC308 Annex A:

- Tabular values are provided for illustration and are applicable for single anchors installed in uncracked normal-weight concrete with minimum slab thickness, $h_a = h_{min}$, and with the following conditions:
 - c_{a1} is greater than or equal to the critical edge distance, c_{ac} where $c_{ac} = 2.7 h_{ef}$.
 - c_{a2} is greater than or equal to 1.5 times c_{a1} .
- Calculations were performed according to ACI 318-05 Appendix D and ICC-ES AC308 Annex A, Section 3.3. The load level corresponding to the failure mode is listed (e.g. For tension: steel, concrete breakout or bond strength; For shear: steel, concrete breakout or pryout strength). The lowest load level controls.
- Strength reduction factors (ϕ) for steel strength and concrete breakout strength were based on ACI 318 Section 9.2 for load combinations. Condition B was assumed.
- Strength reduction factors (ϕ) for bond strength were determined from reliability testing and qualification in accordance with ICC-ES AC308 and are tabulated in this product supplement and ESR-2583.
- Tabular values are permitted for static loads only, seismic loading is not considered with these tables. For seismic design conditions, please see ACI 318-05 Appendix D and ICC-ES AC308 Annex A, Section 3.3 and ESR-2583.
- Periodic special inspection must be performed where required by code or the Authority Having Jurisdiction (AHJ). See ESR-2583.
- Tabular values are not permitted for anchors subjected to tension resulting from sustained loading. Please see ICC-ES AC308 Annex A, Section 3.3 and ESR-2583 for supplemental design requirement for this loading condition.
- For designs that include combined tension and shear, the interaction of tension and shear loads must be calculated in accordance with ACI 318-05 Appendix D.
- Interpolation is not permitted to be used with the tabular values. For intermediate base material compressive strengths, please see ACI 318-05 Appendix D, ICC-ES AC308 Annex A, Section 3.3 and information included in this product supplement. For other design conditions, including seismic, please see ACI 318-05 Appendix D and ICC-ES AC308 Annex A, Section 3.3 and ESR-2583.
- Long term concrete temperatures are roughly constant over significant periods of time. Short-term elevated temperatures are those that occur over brief intervals, e.g. as a result of diurnal cycling.



ADHESIVES

Tension and Shear Design Strength of Steel Elements (Steel Strength)

Nominal Rod/Rebar Size (in. or #)	Steel Elements - Threaded Rod and Reinforcing Bar							
	A 36, Grade C or F 1554 Grade 36		F 593, CW (SS)		A 193, Grade B7		Grade 60 Rebar	
	ϕN_{sa} Tension (lbs.)	ϕN_{sa} Shear (lbs.)	ϕN_{sa} Tension (lbs.)	ϕN_{sa} Shear (lbs.)	ϕN_{sa} Tension (lbs.)	ϕN_{sa} Shear (lbs.)	ϕN_{sa} Tension (lbs.)	ϕN_{sa} Shear (lbs.)
3/8 or #3	3,395	1,765	5,070	2,810	7,315	3,805	7,425	3,860
1/2 or #4	6,175	3,210	9,230	5,110	13,315	6,925	13,500	7,020
5/8 or #5	9,830	5,110	14,690	8,135	21,190	11,020	20,925	10,880
3/4 or #6	14,575	7,580	18,510	10,250	31,405	16,330	29,700	15,455
7/8 or #7	20,095	10,450	25,525	14,135	43,315	22,525	40,500	21,060
1 or #8	26,360	13,710	33,480	18,545	56,815	29,545	53,325	27,730
#9	-	-	-	-	-	-	67,500	35,100
1-1/4	42,150	21,920	53,535	29,650	90,845	47,240	-	-
#10	-	-	-	-	-	-	85,725	44,575

Legend Steel Strength

Factored Design Strength (ϕN_n and ϕV_n) in Accordance with ACI 318 Appendix D and ICC-ES AC308 Annex B:

Tension and Shear Design Strength Installed in Uncracked Concrete, Drilled with a Hammer-Drill and Carbide Bit in a Dry Hole Condition, for Temperature Range A (Bond or Concrete Strength)

ADHESIVES

		Minimum Concrete Compressive Strength, f'_c (psi)									
		2,500		3,000		4,000		6,000		8,000	
Nominal Rod/Rebar Size (in. or #)	Embed. Depth h_{ef} (in.)	N_{cb} or N_a Tension (lbs.)	V_{cb} or V_{cp} Shear (lbs.)	N_{cb} or N_a Tension (lbs.)	V_{cb} or V_{cp} Shear (lbs.)	N_{cb} or N_a Tension (lbs.)	V_{cb} or V_{cp} Shear (lbs.)	N_{cb} or N_a Tension (lbs.)	V_{cb} or V_{cp} Shear (lbs.)	N_{cb} or N_a Tension (lbs.)	V_{cb} or V_{cp} Shear (lbs.)
3/8 or #3	2 3/8	2,855	1,860	3,125	2,035	3,610	2,350	4,265	2,880	4,410	3,325
	3	4,055	2,565	4,440	2,810	5,125	3,245	5,385	3,975	5,575	4,590
	4 1/2	7,270	4,255	7,430	4,660	7,695	5,380	8,075	6,590	8,360	7,610
1/2 or #4	2 3/4	3,555	2,480	3,895	2,715	4,500	3,135	5,510	3,840	6,365	4,435
	4	6,240	4,230	6,835	4,630	7,895	5,350	9,000	6,550	9,315	7,565
	6	11,465	7,150	12,425	7,835	12,860	9,045	13,500	11,080	13,975	12,795
5/8 or #5	3 1/8	4,310	3,260	4,720	3,570	5,450	4,125	6,675	5,050	7,710	5,830
	5	8,720	6,420	9,555	7,030	11,030	8,120	13,405	9,945	13,875	11,480
	7 1/2	16,020	10,945	17,550	11,990	19,150	13,840	20,105	16,955	20,810	19,575
3/4 or #6	3 1/2	5,105	4,350	5,595	4,765	6,460	5,500	7,910	6,740	9,135	7,780
	6	11,465	9,365	12,560	10,255	14,500	11,845	17,760	14,505	19,210	16,750
	9	21,060	15,905	23,070	17,425	26,515	20,120	27,835	24,640	28,810	28,455
7/8 or #7	3 1/2	5,105	4,770	5,595	5,225	6,460	6,035	7,910	7,395	9,135	8,535
	7	14,445	12,685	15,825	13,895	18,275	16,045	22,380	19,650	25,295	22,690
	10 1/2	26,540	21,580	29,070	23,640	33,570	27,295	36,655	33,430	37,945	38,600
1 or #8	4	6,240	6,195	6,835	6,790	7,895	7,840	9,665	9,600	11,160	11,085
	8	17,650	16,510	19,335	18,085	22,325	20,885	27,340	25,580	31,570	29,535
	12	32,425	28,115	35,520	30,795	41,015	35,560	46,515	43,555	48,150	50,290
#9	4 1/2	7,445	8,090	8,155	8,860	9,420	10,230	11,535	12,530	13,320	14,465
	9	21,060	21,295	23,070	23,325	26,640	26,935	32,625	32,985	37,675	38,090
	13 1/2	38,690	36,065	42,380	39,510	48,940	45,620	57,425	55,875	59,445	64,515
1 1/4	5	8,720	9,605	9,555	10,525	11,030	12,150	13,510	14,880	15,600	17,185
	10	24,665	25,670	27,020	28,125	31,200	32,475	38,210	39,770	44,125	45,925
	15	45,315	43,775	49,640	47,950	57,320	55,370	69,280	67,810	71,715	78,305
#10	5	8,720	9,915	9,555	10,860	11,030	12,545	13,510	15,360	15,600	17,740
	10	24,665	26,175	27,020	28,675	31,200	33,110	38,210	40,550	44,125	46,825
	15	45,315	44,390	49,640	48,625	57,320	56,150	69,280	68,765	71,715	79,405

Legend Concrete Breakout Bond Strength/ Pryout Strength

Factored Design Strength (ϕN_n and ϕV_n) in Accordance with ACI 318 Appendix D and ICC-ES AC308 Annex B:

Tension and Shear Design Strength Installed in Uncracked Concrete, Drilled with a Hammer-Drill and Carbide Bit in a Dry Hole Condition, for Temperature Range B (Bond or Concrete Strength)

		Minimum Concrete Compressive Strength, f'_c (psi)									
		2,500		3,000		4,000		6,000		8,000	
Nominal Rod/Rebar Size (in. or #)	Embed. Depth h_{ef} (in.)	N_{cb} or N_a Tension (lbs.)	V_{cb} or V_{cp} Shear (lbs.)	N_{cb} or N_a Tension (lbs.)	V_{cb} or V_{cp} Shear (lbs.)	N_{cb} or N_a Tension (lbs.)	V_{cb} or V_{cp} Shear (lbs.)	N_{cb} or N_a Tension (lbs.)	V_{cb} or V_{cp} Shear (lbs.)	N_{cb} or N_a Tension (lbs.)	V_{cb} or V_{cp} Shear (lbs.)
3/8 or #3	2 3/8	2,110	1,860	2,155	2,035	2,230	2,350	2,345	2,525	2,425	2,610
	3	2,665	2,565	2,725	2,810	2,820	3,245	2,960	3,975	3,065	4,590
	4 1/2	3,995	4,255	4,085	4,660	4,230	5,380	4,440	6,590	4,595	7,610
1/2 or #4	2 3/4	3,065	2,480	3,130	2,715	3,240	3,135	3,405	3,840	3,520	4,435
	4	4,455	4,230	4,555	4,630	4,715	5,350	4,950	6,550	5,125	7,565
	6	6,685	7,150	6,830	7,835	7,070	9,045	7,425	11,080	7,685	12,795
5/8 or #5	3 1/8	4,145	3,260	4,235	3,570	4,385	4,125	4,605	5,050	4,765	5,830
	5	6,630	6,420	6,775	7,030	7,015	8,120	7,365	9,945	7,625	11,480
	7 1/2	9,945	10,945	10,165	11,990	10,520	13,840	11,045	16,955	11,435	19,575
3/4 or #6	3 1/2	5,105	4,350	5,480	4,765	5,670	5,500	5,955	6,740	6,165	7,780
	6	9,190	9,365	9,390	10,255	9,720	11,845	10,205	14,505	10,565	16,750
	9	13,785	15,905	14,090	17,425	14,585	20,120	15,310	24,640	15,850	28,455
7/8 or #7	3 1/2	5,105	4,770	5,595	5,225	6,400	6,035	6,715	7,395	6,955	8,535
	7	12,095	12,685	12,360	13,895	12,795	16,045	13,435	19,650	13,905	22,690
	10 1/2	18,140	21,580	18,545	23,640	19,195	27,295	20,150	33,430	20,860	38,600
1 or #8	4	6,240	6,195	6,835	6,790	7,895	7,840	8,520	9,600	8,820	11,085
	8	15,340	16,510	15,680	18,085	16,230	20,885	17,040	25,580	17,635	29,535
	12	23,010	28,115	23,520	30,795	24,345	35,560	25,560	43,555	26,455	50,290
#9	4 1/2	7,445	8,090	8,155	8,860	9,420	10,230	10,530	12,530	10,900	14,465
	9	18,960	21,295	19,380	23,325	20,060	26,935	21,060	32,985	21,800	38,090
	13 1/2	28,440	36,065	29,070	39,510	30,090	45,620	31,590	55,875	32,700	64,515
1 1/4	5	8,720	9,605	9,555	10,525	11,030	12,150	12,700	14,880	13,150	17,185
	10	22,870	25,670	23,375	28,125	24,200	32,475	25,405	39,770	26,295	45,925
	15	34,305	43,775	35,065	47,950	36,295	55,370	38,105	67,810	39,445	78,305
#10	5	8,720	9,915	9,555	10,860	11,030	12,545	12,700	15,360	13,150	17,740
	10	22,870	26,175	23,375	28,675	24,200	33,110	25,405	40,550	26,295	46,825
	15	34,305	44,390	35,065	48,625	36,295	56,150	38,105	68,765	39,445	79,405

Legend Concrete Breakout Bond Strength/Pryout Strength

ADHESIVES

Factored Design Strength (ϕN_n and ϕV_n) in Accordance with ACI 318 Appendix D and ICC-ES AC308 Annex B:

Tension and Shear Design Strength Installed in Cracked Concrete, Drilled with a Hammer-Drill and Carbide Bit in a Dry Hole Condition, for Temperature Range A (Bond or Concrete Strength)

ADHESIVES

		Minimum Concrete Compressive Strength, f'_c (psi)									
		2,500		3,000		4,000		6,000		8,000	
Nominal Rod/Rebar Size (in. or #)	Embed. Depth h_{ef} (in.)	N_{cb} or N_a Tension (lbs.)	V_{cb} or V_{cp} Shear (lbs.)	N_{cb} or N_a Tension (lbs.)	V_{cb} or V_{cp} Shear (lbs.)	N_{cb} or N_a Tension (lbs.)	V_{cb} or V_{cp} Shear (lbs.)	N_{cb} or N_a Tension (lbs.)	V_{cb} or V_{cp} Shear (lbs.)	N_{cb} or N_a Tension (lbs.)	V_{cb} or V_{cp} Shear (lbs.)
1/2 or #4	2 3/4	2,520	1,770	2,755	1,940	2,850	2,240	2,995	2,740	3,100	3,165
	4	3,920	3,020	4,005	3,310	4,150	3,820	4,355	4,680	4,510	5,405
	6	5,880	5,110	6,010	5,595	6,220	6,460	6,535	7,915	6,760	9,140
5/8 or #5	3 1/8	3,050	2,330	3,210	2,550	3,325	2,945	3,490	3,610	3,615	4,165
	5	5,030	4,585	5,140	5,020	5,320	5,800	5,585	7,100	5,780	8,200
	7 1/2	7,545	7,815	7,710	8,565	7,980	9,885	8,380	12,110	8,675	13,985
3/4 or #6	3 1/2	3,620	3,105	3,965	3,405	4,155	3,930	4,365	4,815	4,520	5,555
	6	6,735	6,690	6,885	7,325	7,125	8,460	7,480	10,360	7,745	11,965
	9	10,105	11,360	10,325	12,445	10,690	14,370	11,225	17,600	11,615	20,325
7/8 or #7	3 1/2	3,620	3,410	3,965	3,735	4,570	4,310	4,800	5,280	4,970	6,095
	7	8,645	9,060	8,835	9,925	9,145	11,460	9,600	14,035	9,935	16,210
	10 1/2	12,965	15,415	13,250	16,885	13,715	19,495	14,400	23,880	14,905	27,570
1 or #8	4	4,420	4,425	4,840	4,850	5,590	5,600	6,270	6,860	6,490	7,920
	8	11,290	11,795	11,540	12,920	11,945	14,920	12,540	18,270	12,980	21,095
	12	16,935	20,080	17,305	21,995	17,915	25,400	18,810	31,110	19,470	35,920
#9	4 1/2	5,275	5,775	5,780	6,330	6,670	7,305	7,935	8,950	8,215	10,335
	9	14,285	15,210	14,605	16,660	15,115	19,240	15,870	23,560	16,425	27,205
	13 1/2	21,430	25,760	21,905	28,220	22,675	32,585	23,805	39,910	24,640	46,085
1 1/4	5	6,175	6,860	6,765	7,515	7,815	8,680	9,570	10,630	10,140	12,275
	10	17,470	18,335	18,030	20,090	18,660	23,195	19,590	28,410	20,280	32,805
	15	26,455	31,265	27,040	34,250	27,990	39,550	29,390	48,435	30,420	55,930
#10	5	6,175	7,085	6,765	7,760	7,815	8,960	9,570	10,970	10,140	12,670
	10	17,470	18,695	18,030	20,480	18,660	23,650	19,590	28,965	20,280	33,445
	15	26,455	31,705	27,040	34,735	27,990	40,105	29,390	49,120	30,420	56,720

Legend Concrete Breakout Bond Strength/Pryout Strength

Factored Design Strength (ϕN_n and ϕV_n) in Accordance with ACI 318 Appendix D and ICC-ES AC308 Annex B (Continued):

Tension and Shear Design Strength Installed in Cracked Concrete, Drilled with a Hammer-Drill and Carbide Bit in a Dry Hole Condition, for Temperature Range B (Bond or Concrete Strength)

		Minimum Concrete Compressive Strength, f'_c (psi)									
		2,500		3,000		4,000		6,000		8,000	
Nominal Rod/Rebar Size (in. or #)	Embed. Depth h_{ef} (in.)	N_{cb} or N_a Tension (lbs.)	V_{cb} or V_{cp} Shear (lbs.)	N_{cb} or N_a Tension (lbs.)	V_{cb} or V_{cp} Shear (lbs.)	N_{cb} or N_a Tension (lbs.)	V_{cb} or V_{cp} Shear (lbs.)	N_{cb} or N_a Tension (lbs.)	V_{cb} or V_{cp} Shear (lbs.)	N_{cb} or N_a Tension (lbs.)	V_{cb} or V_{cp} Shear (lbs.)
1/2 or #4	2 3/4	1,480	1,770	1,510	1,940	1,565	2,240	1,645	2,740	1,700	3,165
	4	2,150	3,020	2,200	3,310	2,275	3,820	2,390	4,680	2,475	5,330
	6	3,230	5,110	3,300	5,595	3,415	6,460	3,585	7,725	3,710	7,995
5/8 or #5	3 1/8	1,730	2,330	1,770	2,550	1,830	2,945	1,925	3,610	1,990	4,165
	5	2,770	4,585	2,830	5,020	2,930	5,800	3,075	6,625	3,185	6,860
	7 1/2	4,155	7,815	4,245	8,565	4,395	9,465	4,615	9,940	4,775	10,290
3/4 or #6	3 1/2	2,165	3,105	2,215	3,405	2,290	3,930	2,405	4,815	2,490	5,365
	6	3,710	6,690	3,795	7,325	3,930	8,460	4,125	8,880	4,270	9,195
	9	5,570	11,360	5,690	12,260	5,890	12,690	6,185	13,325	6,405	13,790
7/8 or #7	3 1/2	2,375	3,410	2,430	3,735	2,515	4,310	2,640	5,280	2,730	5,885
	7	4,755	9,060	4,860	9,925	5,030	10,830	5,280	11,370	5,465	11,770
	10 1/2	7,130	15,355	7,285	15,695	7,545	16,245	7,920	17,055	8,195	17,655
1 or #8	4	3,105	4,425	3,175	4,850	3,285	5,600	3,450	6,860	3,570	7,685
	8	6,210	11,795	6,345	12,920	6,570	14,145	6,895	14,850	7,140	15,375
	12	9,310	20,055	9,520	20,500	9,850	21,220	10,345	22,280	10,705	23,060
#9	4 1/2	3,930	5,775	4,015	6,330	4,155	7,305	4,365	8,950	4,515	9,730
	9	7,855	15,210	8,030	16,660	8,315	17,905	8,725	18,795	9,035	19,455
	13 1/2	11,785	25,385	12,045	25,945	12,470	26,855	13,090	28,195	13,550	29,185
1 1/4	5	4,850	6,860	4,955	7,515	5,130	8,680	5,385	10,630	5,575	12,010
	10	9,700	18,335	9,915	20,090	10,260	22,105	10,775	23,205	11,155	24,020
	15	14,550	31,265	14,870	32,030	15,395	33,155	16,160	34,810	16,730	36,030
#10	5	4,850	7,085	4,955	7,760	5,130	8,960	5,385	10,970	5,575	12,010
	10	9,700	18,695	9,915	20,480	10,260	22,105	10,775	23,205	11,155	24,020
	15	14,550	31,335	14,870	32,030	15,395	33,155	16,160	34,810	16,730	36,030

Legend Concrete Breakout Bond Strength/Pryout Strength

ADHESIVES

Factored Design Strength (ϕN_n and ϕV_n) in Accordance with ACI 318 Appendix D and ICC-ES AC308 Annex A: (Continued):

Tension and Shear Design Strength Installed in Uncracked Concrete, Drilled with a Core-Drill and Diamond Core Bit in a Dry Hole Condition, for Temperature Range A (Bond or Concrete Strength)

		Minimum Concrete Compressive Strength, f'_c (psi)									
		2,500		3,000		4,000		6,000		8,000	
Nominal Rod/Rebar Size (in. or #)	Embed. Depth h_{ef} (in.)	ϕN_{cb} or ϕN_a Tension (lbs.)	ϕV_{cb} or ϕV_{cp} Shear (lbs.)	ϕN_{cb} or ϕN_a Tension (lbs.)	ϕV_{cb} or ϕV_{cp} Shear (lbs.)	ϕN_{cb} or ϕN_a Tension (lbs.)	ϕV_{cb} or ϕV_{cp} Shear (lbs.)	ϕN_{cb} or ϕN_a Tension (lbs.)	ϕV_{cb} or ϕV_{cp} Shear (lbs.)	ϕN_{cb} or ϕN_a Tension (lbs.)	ϕV_{cb} or ϕV_{cp} Shear (lbs.)
1/2 or #4	2 3/4	3,370	2,480	3,445	2,715	3,565	3,135	3,745	3,840	3,875	4,435
	4	4,905	4,230	5,010	4,630	5,190	5,350	5,445	6,550	5,640	7,565
	6	7,355	7,150	7,520	7,835	7,780	9,045	8,170	11,080	8,455	12,795
5/8 or #5	3 1/8	3,730	3,260	3,815	3,570	3,945	4,125	4,145	5,050	4,290	5,830
	5	5,970	6,420	6,100	7,030	6,315	8,120	6,630	9,945	6,865	11,480
	7 1/2	8,955	10,945	9,150	11,990	9,470	13,840	9,945	16,955	10,295	19,575
3/4 or #6	3 1/2	4,815	4,350	4,925	4,765	5,095	5,500	5,350	6,740	5,540	7,780
	6	8,260	9,365	8,440	10,255	8,735	11,845	9,170	14,505	9,495	16,750
	9	12,385	15,905	12,660	17,425	13,105	20,120	13,760	24,640	14,240	28,455
7/8 or #7	3 1/2	5,105	4,770	5,565	5,225	5,760	6,035	6,045	7,395	6,255	8,535
	7	10,885	12,685	11,125	13,895	11,515	16,045	12,090	19,650	12,515	22,690
	10 1/2	16,325	21,580	16,690	23,640	17,275	27,295	18,135	33,430	18,770	37,545
1 or #8	4	6,240	6,195	6,835	6,790	7,305	7,840	7,670	9,600	7,940	11,085
	8	13,810	16,510	14,115	18,085	14,610	20,885	15,340	25,580	15,880	29,535
	12	20,715	28,115	21,170	30,795	21,915	35,560	23,010	43,555	23,815	47,635

Legend Concrete Breakout Bond Strength/Pryout Strength

Tension and Shear Design Strength Installed in Uncracked Concrete, Drilled with a Core-Drill and Diamond Core Bit in a Dry Hole Condition, for Temperature Range B (Bond or Concrete Strength)

		Minimum Concrete Compressive Strength, f'_c (psi)									
		2,500		3,000		4,000		6,000		8,000	
Nominal Rod/Rebar Size (in. or #)	Embed. Depth h_{ef} (in.)	ϕN_{cb} or ϕN_a Tension (lbs.)	ϕV_{cb} or ϕV_{cp} Shear (lbs.)	ϕN_{cb} or ϕN_a Tension (lbs.)	ϕV_{cb} or ϕV_{cp} Shear (lbs.)	ϕN_{cb} or ϕN_a Tension (lbs.)	ϕV_{cb} or ϕV_{cp} Shear (lbs.)	ϕN_{cb} or ϕN_a Tension (lbs.)	ϕV_{cb} or ϕV_{cp} Shear (lbs.)	ϕN_{cb} or ϕN_a Tension (lbs.)	ϕV_{cb} or ϕV_{cp} Shear (lbs.)
1/2 or #4	2 3/4	2,550	2,480	2,610	2,715	2,700	3,135	2,835	3,840	2,935	4,435
	4	3,710	4,230	3,795	4,630	3,925	5,350	4,125	6,550	4,265	7,565
	6	5,565	7,150	5,690	7,835	5,890	9,045	6,185	11,080	6,400	12,795
5/8 or #5	3 1/8	2,825	3,260	2,885	3,570	2,990	4,125	3,140	5,050	3,250	5,830
	5	4,520	6,420	4,620	7,030	4,780	8,120	5,020	9,945	5,195	11,480
	7 1/2	6,780	10,945	6,930	11,990	7,175	13,840	7,530	16,955	7,795	19,575
3/4 or #6	3 1/2	3,650	4,350	3,730	4,765	3,860	5,500	4,050	6,740	4,195	7,780
	6	6,255	9,365	6,390	10,255	6,615	11,845	6,945	14,505	7,190	16,750
	9	9,380	15,905	9,590	17,425	9,925	20,120	10,420	24,640	10,785	28,455
7/8 or #7	3 1/2	4,115	4,770	4,210	5,225	4,355	6,035	4,575	7,395	4,735	8,535
	7	8,235	12,685	8,415	13,895	8,715	16,045	9,145	19,650	9,470	22,690
	10 1/2	12,350	21,580	12,625	23,640	13,070	27,295	13,720	33,430	14,200	38,600
1 or #8	4	5,225	6,195	5,340	6,790	5,530	7,840	5,805	9,600	6,010	11,085
	8	10,450	16,510	10,680	18,085	11,055	20,885	11,610	25,580	12,015	29,535
	12	15,675	28,115	16,020	30,795	16,585	35,560	17,410	43,555	18,025	50,290

Legend Concrete Breakout Bond Strength/Pryout Strength

Allowable Load Capacities for PE1000+ Installed into Uncracked Normal-Weight Concrete with Threaded Rod and Reinforcing Bar (Based on Bond Strength/Concrete Capacity)^{1,2,3,4,5,6}

Nominal Rod/Rebar Size (in. or #)	Minimum Embedment Depth (in.)	Minimum Concrete Compressive Strength, (f'c)			
		3,000 psi	4,000 psi	5,000 psi	6,000 psi
		Tension (lbs)			
3/8 or #3	2 3/8	1,195	1,235	1,270	1,300
	3 1/2	1,760	1,825	1,875	1,915
	4 1/2	2,265	2,345	2,410	2,460
1/2 or #4	2 3/4	1,770	1,835	1,885	1,925
	4 3/8	2,820	2,915	2,995	3,065
	6	3,865	4,000	4,110	4,200
5/8 or #5	3 1/8	2,420	2,505	2,575	2,630
	5 1/4	4,145	4,290	4,405	4,505
	7 1/2	5,970	6,180	6,345	6,485
3/4 or #6	3 1/2	2,870	2,970	3,050	3,120
	6 1/4	5,715	5,915	6,075	6,210
	9	8,560	8,860	9,100	9,300
7/8 or #7	3 1/2	2,870	2,970	3,050	3,120
	7	7,285	7,540	7,745	7,915
	10 1/2	11,700	12,110	12,440	12,715
1 or #8	4	3,505	3,630	3,725	3,810
	8	9,570	9,905	10,175	10,400
	12	15,635	16,185	16,625	16,990
1-1/8 or #9	4 1/2	4,185	4,330	4,445	4,545
	9	12,025	12,445	12,785	13,065
	13 1/2	19,865	20,560	21,120	21,585
1-1/4 or #10	5	4,900	5,070	5,210	5,325
	10	15,030	15,560	15,980	16,335
	15	25,165	26,045	26,755	27,345

ADHESIVES

1. Allowable load capacities listed are calculated using an applied safety factor of 4.0. Consideration of safety factors of 10 or higher may be necessary depending on the application, such as life safety or overhead.
2. Linear interpolation may be used to determine allowable loads for intermediate embedments and compressive strengths.
3. The tabulated load values are applicable to single anchors installed at critical edge and spacing distances and where the minimum member thickness is greater of $[h_{ef} + 1-1/4"]$ and $[h_{ef} + 2d_0]$.
4. The tabulated load values are for applicable for dry concrete. Holes must be drilled with a hammer drill and an ANSI carbide drill bit. Installations in wet concrete or in water-filled holes may require a reduction in capacity. Contact Powers Fasteners for more information concerning these installation conditions.
5. Adhesives experience reductions in capacity at elevated temperatures. See the in-service temperature chart for allowable load capacities.
6. Allowable bond strength/concrete capacity must be checked against allowable steel strength in tension to determine the controlling allowable load.

Allowable Load Capacities for PE1000+ Installed into Uncracked Normal-Weight Concrete with Threaded Rod and Reinforcing Bar (Based on Steel Strength)^{1,2,3,4,5}



ADHESIVES

Nominal Rod or Rebar Size (in. or #)	Steel Elements - Threaded Rod and Reinforcing Bar							
	A36 or F1554 Grade 36		A 193, Grade B7		F 593, CW (SS)		Grade 60 Rebar	
	Tension (lbs)	Shear (lbs)	Tension (lbs)	Shear (lbs)	Tension (lbs)	Shear (lbs)	Tension (lbs)	Shear (lbs)
3/8 or #3	1,485	760	3,085	1,585	2,565	1,315	2,655	1,320
1/2 or #4	2,725	1,395	5,655	2,900	4,685	2,410	4,710	2,345
5/8 or #5	4,325	2,225	8,990	4,625	7,480	3,845	7,370	3,670
3/4 or #6	6,420	3,295	13,320	6,845	9,465	4,865	10,592	5,285
7/8 or #7	8,855	4,550	18,390	9,445	13,070	6,715	14,425	7,195
1 or #8	11,630	5,970	24,115	12,395	17,150	8,810	18,840	9,595
#9	-	-	-	-	-	-	23,845	11,890
1-1/4	18,595	9,555	38,585	19,830	27,430	14,095		
#10	-	-	-	-	-	-	29,435	14,680

1. Allowable load capacities listed are calculated for the steel element type. Consideration of applying additional safety factors may be necessary depending on the application, such as life safety or overhead.
2. The tabulated load values are applicable to single anchors at critical edge and spacing distances and where the minimum member thickness is 2.7 times the embedment depth.
3. The tabulated load values are for dry concrete. Holes must be drilled with a hammer drill and an ANSI carbide drill bit. Installation in wet concrete or installations in water-filled holes may require a reduction in capacity. Contact Powers Fasteners for more information concerning these installation conditions.
4. Allowable shear capacity is controlled by steel strength for the given conditions.
5. Allowable bond strength/concrete capacity must be checked against allowable steel strength in tension to determine the controlling allowable load.

In-Service Temperature Chart for Allowable Load Capacities¹

Base Material Temperature		Bond Strength Reduction Factor for Temperature
°F	°C	
41	5	1.00
50	10	1.00
68	20	1.00
75	14	1.00
104	40	0.85
110	43	0.82
122	50	0.76
140	60	0.69

1. Linear interpolation may be used to derive reduction factors between those listed.

Ultimate Load Capacities for Threaded Rod Installed with PE1000+ into the Block Face of Grout-Filled Concrete Masonry Walls^{1,2}



Rod Diameter <i>d</i> in. (mm)	Drill Diameter <i>d_{bit}</i> in.	Minimum Embedment Depth in. (mm)	Minimum Edge Distance in. (mm)	Minimum End Distance in. (mm)	Ultimate Load ³		Allowable Load	
					Tension lbs. (kN)	Shear lbs. (kN)	Tension lbs. (kN)	Shear lbs. (kN)
3/8 (9.5)	7/16	3 (76.2)	2-1/2 (63.5)	2-1/2 (63.5)	3,350 (14.9)	2,100 (9.3)	670 (2.9)	420 (1.9)
1/2 (12.7)	9/16	4 (101.6)	3 (76.2)	3 (76.2)	4,575 (20.3)	2,550 (11.3)	915 (4.1)	510 (2.3)
5/8 (15.9)	11/16	5 (127.0)	3-3/4 (95.3)	4 (101.6)	6,900 (30.7)	5,275 (23.5)	1,380 (6.1)	1,055 (4.7)

1. Tabulated load values are for anchors installed in minimum 8" wide, minimum Grade N, Type II, lightweight, medium-weight or normal-weight concrete masonry units conforming to ASTM C 90 that have reached a designated minimum compressive strength at the time of installation ($f'_m \geq 1,500$ psi). Mortar must be type N, S or M.
2. Anchor installations are limited to one per masonry cell. Shear loads may be applied in any direction.
3. The values listed are ultimate load capacities which should be reduced by a minimum safety factor of 5.0 or greater to determine the allowable working load. Consideration of safety factors of 10 or higher may be necessary depending on the application, such as life safety.

Ultimate Load Capacities for Threaded Rod Installed with PE1000+ into the Top of Grout-Filled Concrete Masonry Walls^{1,2}

Rod Diameter <i>d</i> in. (mm)	Drill Diameter <i>d_{bit}</i> in.	Minimum Embedment Depth in. (mm)	Minimum Edge Distance in. (mm)	Minimum End Distance in. (mm)	Ultimate Load ²		Allowable Load	
					Tension lbs. (kN)	Shear lbs. (kN)	Tension lbs. (kN)	Shear lbs. (kN)
1/2 (12.7)	9/16	6 (152.4)	1-3/4 (44.5)	3 (76.2)	5,950 (26.4)	1,450 (6.5)	1,190 (5.3)	290 (1.3)
5/8 (15.9)	11/16	8 (203.2)	1-3/4 (44.5)	4 (101.6)	9,450 (42.0)	1,700 (7.5)	1,890 (8.4)	340 (1.4)

1. Tabulated load values are for anchors installed in a minimum Grade N, Type II, lightweight, medium-weight or normal-weight masonry units conforming to ASTM C 90 that have reached a designated ultimate compressive strength at the time of installation ($f'_m \geq 1,500$ psi). Mortar must be type N, S or M.
2. Anchor installations are limited to one per masonry cell. Shear loads may be applied in any direction.
3. The values listed are ultimate load capacities which should be reduced by a minimum safety factor of 5.0 or greater to determine the allowable working load. Consideration of safety factors of 10 or higher may be necessary depending on the application, such as life safety.

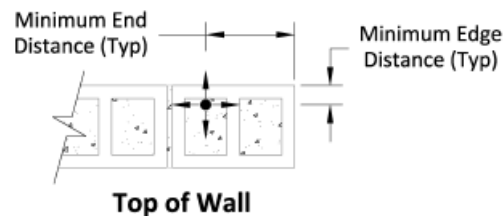
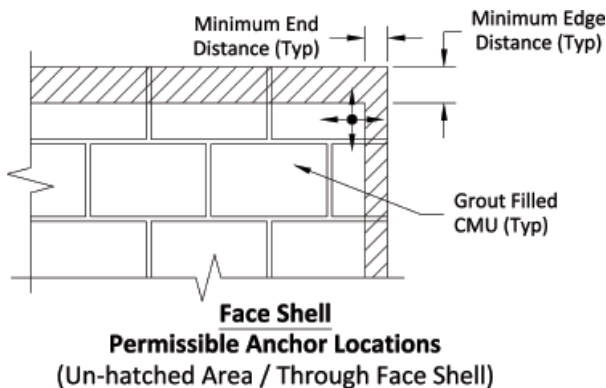

ADHESIVES

ORDERING INFORMATION

PE1000+ Cartridges

Cat No.	Description	Std. Carton	Pallet
0500SD	PE1000+ 13 fl. oz. dual cartridge	12	540
0502SD	PE1000+ 20 fl. oz. dual cartridge	12	540
0503SD	PE1000+ 47 fl. oz. dual cartridge	12	624



One PE1000+ mixing nozzle is packaged with each cartridge.
PE1000+ mixing nozzles must be used to ensure complete and proper mixing of the adhesive.

Cartridge System Mixing Nozzles

Cat No.	Description	Std. Pack/Box	Std. Carton
08294	Extra mixing nozzle (with a 8" extension) for PE1000+	2	24
08281	Mixing nozzle extension, 8" minimum	2	24



Dispensing Tools for Injection Adhesive

Cat No.	Description	Std. Box	Std. Carton
08298	13 fl. oz. and 20 fl. oz.. Manual tool	1	6
8497SD	20 fl. oz. Pnuematic tool	1	-
08275	47 fl. oz. Pnuematic tool	1	-



PE1000+ Epoxy Adhesive Anchor System



Hole Cleaning Tools and Accessories

Cat No.	Description	Std. Package
08284	Wire brush for 7/16" ANSI hole (3/8" rod or #3 rebar)	1
08285	Wire brush for 9/16" ANSI hole (1/2" rod or #4 rebar)	1
08286	Wire brush for 11/16" ANSI hole (5/8" rod or #5 rebar)	1
08278	Wire brush for 3/4" ANSI hole (5/8" rod or #5 rebar)	1
08287	Wire brush for 7/8" ANSI hole (3/4" rod or #6 rebar)	1
08288	Wire brush for 1" ANSI hole (7/8" rod or #7 rebar)	1
08289	Wire brush for 1-1/8" ANSI hole (1" rod or #8 rebar)	1
08290	Wire brush for 1-3/8" ANSI hole (1-1/4" rod or #9 rebar)	1
08291	Wire brush for 1-1/2" ANSI hole (#10 rebar)	1
08283	SDS-plus adapter for steel brushes	1
08296	Standard drill adapter for steel brushes (e.g. Jacobs Chuck)	1
08282	Steel brush extension, 12"	1
08280	Hand pump/dust blower (25 fl. oz. cylinder volume)	1
08292	Air compressor nozzle with extension	1
08465	Adjustable torque wrench with 1/2" square drive (10 to 150 ft.-lbs.)	1
08466	Adjustable torque wrench with 1/2" square drive (25 to 250 ft.-lbs.)	1
52073	Adhesive cleaning kit, includes 4 wire brushes (08284, 08285, 08286, 08287), steel brush extension (08282), SDS-plus adapter (08283), standard drill adapter (08296), hand pump/dust blower (08280), gloves and safety glasses	1

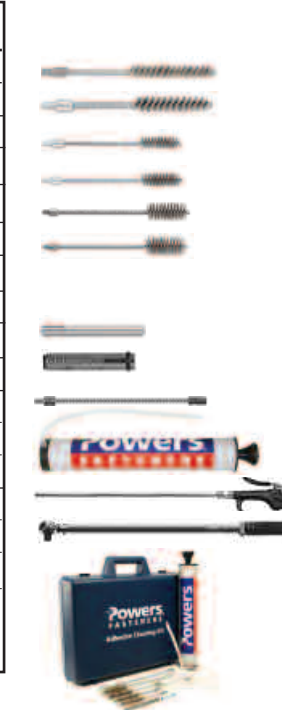

ADHESIVES