

Tapper+ Concrete Screw Anchor

PRODUCT DESCRIPTION

The Tapper+ fastening system is a complete family of screw anchors for light to medium duty applications in concrete, masonry block, brick, and wood base materials. The Tapper+ is fast and easy to install and provides a neat, finished appearance. The Tapper+ screw anchor is engineered with matched tolerance drill bits and installation tools designed to meet the needs of the user and also provide optimum performance. The Tapper+ features a gimlet point for self-drilling into wood base materials without pre-drilling.

The Tapper+ screw anchor is available in carbon steel with a Perma-Seal climate coating in several colors. Head styles include a slotted hex washer head, Phillips flat head, trim Phillips flat head and Hex flange washer head.

GENERAL APPLICATIONS AND USES

- Window installations
- Interior hand rails
- Metal door frames
- Joint flashing
- Storm shutters
- Interior lighting fixtures
- Thresholds
- Screened Enclosures

FEATURES AND BENEFITS

- + Available in several head styles
- + Several colors and finishes to match application
- + Removable (reusable in wood)
- + High-low thread design for greater stability and grip
- + Does not exert expansion forces
- + No hole spotting required
- + Good corrosion protection with Perma-Seal coating
- + Gimlet point for self drilling into wood base material

APPROVALS

International Code Council, Evaluation Service (ICC-ES), ESR-3068 for uncracked concrete (including FBC supplement), ESR-3042 for wood, ESR-3213 for chemically treated lumber. Code compliant with the International Building Code (IBC) and the International Residential Code (IRC).

Tested in accordance with ACI 355.2 and ICC-ES AC193 (including ASTM E 488) for use in structural concrete, ICC-ES AC106 for use in masonry, ICC-ES AC233 for use in wood, and ICC-ES AC257 for use in pressure treated lumber

Evaluated and qualified by an accredited independent testing laboratory for reliability against brittle failure, e.g. hydrogen embrittlement

Miami-Dade County Notice of Acceptance (NOA) 10-0505.05

GUIDE SPECIFICATIONS

CSI Divisions: 03 16 00 - Concrete Anchors, 04 05 19.16 - Masonry Anchors, 05 05 19 - Post-Installed Concrete Anchors and 06 05 23 - Wood, Plastic, and Composite Fastenings. Concrete Screw Anchors shall be Tapper+ anchors as supplied by Powers Fasteners, Inc., Brewster, NY.

MATERIAL SPECIFICATIONS

Anchor Component	Perma-Seal Tapper
Anchor Body	Case hardened carbon steel
Coating/Plating/Finish	Perma-seal coating (various colors)

SECTION CONTENTS Page No.

General Information 1
 Installation Specifications 2
 ASD Installation Specifications 3
 Reference Performance Data 4
 ASD Design Criteria..... 5
 Masonry Performance Data 6
 Strength Design Information 9
 SD Performance Data..... 12
 Ordering Information 13

MECHANICAL ANCHORS



Perma-Seal Coated Carbon Steel Tapper+

ANCHOR MATERIALS

Carbon Steel with Perma-Seal Coating

ANCHOR SIZE RANGE (TYP.)

- 3/16" diameter x 1-1/4" to 4" lengths
- 1/4" diameter x 1-1/4" to 6" lengths
- 5/16" diameter x 1-3/4" to 6" lengths

SUITABLE BASE MATERIALS

- Normal-weight Concrete
- Lightweight Concrete
- Grouted Concrete Masonry,
- Hollow Concrete Masonry (CMU)
- Solid Brick Masonry
- Wood



This Product Available In



Powers Design Assist
 Real Time Anchor Design Software
www.powersdesignassist.com

INSTALLATION SPECIFICATIONS

Perma-Seal Carbon Steel Hex Head Tapper+

Dimension	Anchor Diameter, d		
	3/16"	1/4"	5/16"
Tapper+ Drill Bit Size, d_{bit} (in.)	5/32"	3/16"	1/4"
Fixture Clearance Hole, d_h (in.)	1/4"	5/16"	5/16"
Head Height (in.)	7/64"	9/64"	1/4"
Hex Head Wrench/Socket Size	1/4"	5/16"	5/16"
Washer O.D., d_w (in.)	11/32"	13/32"	9/16"
Washer Thickness, (in.)	1/32"	1/32"	1/16"

Perma-Seal Carbon Steel Flat Head Tapper+

Dimension	Anchor Diameter, d		
	3/16"	1/4"	5/16"
Tapper+ Drill Bit Size, d_{bit} (in.)	5/32"	3/16"	1/4"
Fixture Clearance Hole, d_h (in.)	1/4"	5/16"	5/16"
Phillips Head O.D., (in.)	3/8"	1/2"	9/16"
Phillips Head Height, (in.)	9/64"	3/16"	9/32"
Phillips Bit Size (No.)	2	3	3

Installation Procedure

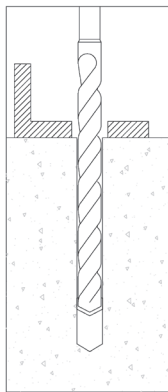

1.) Using the proper Tapper+ drill bit size, drill a hole into the base material to the required depth. The tolerances of the Tapper+ bit used must meet the requirements of the published range in Table 1.

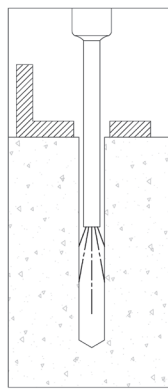

2.) Remove dust and debris from hole using a hand pump, compressed air or a vacuum to remove loose particles left from drilling.

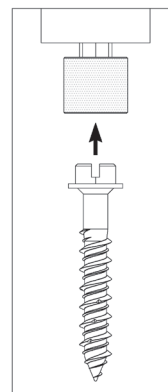

3.) For 3/16" and 1/4" sizes, attach a Tapper 1000 installation socket tool for the selected anchor size to a percussion drill and set the drill to rotary only mode. Mount the screw anchor head into the socket. For flat head versions a phillips bit tip must be used with the socket tool.

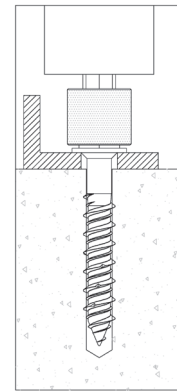

4.) For 3/16" and 1/4" sizes, place the point of the Tapper+ anchor through the fixture into the predrilled hole and drive the anchor until it is fully seated at the proper embedment. The socket tool will automatically disengage from the head of the Tapper+.

Note: Step #1 and #2 not applicable for wood base materials, drill bit not applicable for wood base materials.

For the 5/16" size, select a powered impact wrench that does not exceed the maximum torque, T_{screw} , for the selected anchor diameter. Attach an appropriate sized hex socket or phillips bit to the impact wrench. Mount the screw anchor head into the socket or phillips bit.

For the 5/16" size, drive the anchor with an impact wrench through the fixture and into the hole until the head of the anchor comes into contact with the fixture. The anchor must be snug after installation. Do not spin the hex socket or phillips bit off the anchor to disengage.

Head Marking



Legend

- 'P' Marking = Powers Tapper +
- '+' Symbol = Strength Design Compliant Anchor
- Length Identification Mark
- ★ = 5/16" Diameter Identification mark

Matched Tolerance System

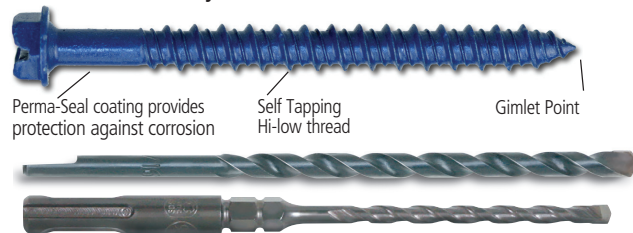

Designed and tested as a system for consistency and reliability

Tapper+ Length Code Identification System

Length ID marking on head		□	A	B	C	D	E	F	G	H	I	J
Overall anchor length l_{anchor} (inches)	From	1	1-1/2	2	2-1/2	3	3-1/2	4	4-1/2	5	5-1/2	6
	Up to but not including	1-1/2	2	2-1/2	3	3-1/2	4	4-1/2	5	5-1/2	6	6-1/2

INSTALLATION SPECIFICATIONS



Installation Table for Tapper+ in Concrete

Anchor Property/Setting Information	Notation	Units	Nominal Anchor Size (in.)		
			3/16	1/4	5/16
Anchor outside diameter	d	in. (mm)	0.145 (3.7)	0.185 (4.7)	0.250 (6.4)
Nominal drill bit diameter	d_{bit}	in. (mm)	3/16 Tapper+ Bit	1/4 Tapper+ Bit	5/16 Tapper+ Bit
Tapper+ bit tolerance range	-	in.	0.170 to 0.176	0.202 to 0.207	0.255 to 0.259
Minimum embedment depth	h_v	in. (mm)	1-3/4 (44.4)	1-3/4 (44.4)	1-7/8 (47.6)
Minimum hole depth	h_o	in. (mm)	2 (50.8)	2 (50.8)	2-1/4 (57)
Hex Head Socket Size	-	-	1/4	5/16	5/16
Phillips Bit Size	-	-	2	3	3
Max Impact Wrench Power	T_{screw}	ft-lbs (N-m)	-	-	115 (150)

For SI: 1 inch = 25.4 mm, 1 ft-lbf = 1.356 N-m.

Installation Table for Tapper+ in Masonry

Anchor Property/Setting Information	Notation	Units	Nominal Anchor Size (in.)		
			3/16	1/4	5/16
Anchor outside diameter	d	in. (mm)	0.145 (3.2)	0.185 (4.7)	0.250 (6.4)
Nominal drill bit diameter	d_{bit}	in. (mm)	3/16 Tapper+ Bit	1/4 Tapper+ Bit	5/16 Tapper+ Bit
Tapper+ bit tolerance range	-	in.	0.170 to 0.176	0.202 to 0.207	0.255 to 0.259
Minimum embedment depth (Grout Filled Masonry)	h_v	in. (mm)	1-1/2 (38.1)	1-1/2 (38.1)	2-1/2 (63.5)
Minimum hole depth (Grout Filled Masonry)	h_o	in. (mm)	1-3/4 (44.4)	1-3/4 (44.4)	2-3/4 (69.9)
Minimum embedment depth (Hollow Masonry)	h_v	in. (mm)	1 (25.4)	1 (25.4)	1-1/2 (38.1)
Minimum hole depth (Hollow Masonry)	h_o	in. (mm)	1-1/4 (31.8)	1-1/4 (31.8)	1-3/4 (44.5)
Hex Head Socket Size	-	-	1/4	5/16	5/16
Phillips Bit Size	-	-	2	3	3

Installation Table for Tapper+ in Wood

Anchor Property/Setting Information	Notation	Units	Nominal Anchor Size (in.)	
			3/16	1/4
Anchor outside diameter	d	in. (mm)	0.145 (3.7)	0.185 (4.7)
Nominal drill bit diameter	d_{bit}	in. (mm)	Pre-drilling is not required for Tapper+ into wood	
Hex Head Socket Size	-	-	1/4	5/16
Phillips Bit Size	-	-	2	3

Tapper+ Anchor Detail

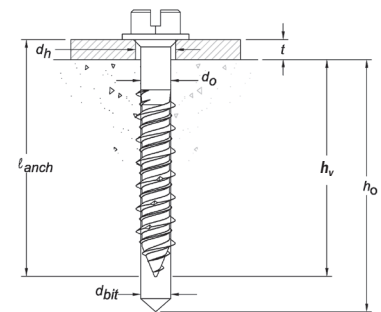

(Slotted hex head version pictured, flat head length measured from bottom of head to tip of anchor)

REFERENCE PERFORMANCE DATA

Ultimate Load Capacities for Tapper+ in Normal-Weight Concrete^{1,2}

Nominal Anchor Diameter d in.	Minimum Embedment Depth in. (mm)	Minimum Concrete Compressive Strength									
		f'c = 2,500 psi (17.3 MPa)		f'c = 3,000 psi (20.7 MPa)		f'c = 4,000 psi (27.6 MPa)		f'c = 6,000 psi (41.4 MPa)		f'c = 8,000 psi (55.2 MPa)	
		Tension lbs. (kN)	Shear lbs. (kN)	Tension lbs. (kN)	Shear lbs. (kN)	Tension lbs. (kN)	Shear lbs. (kN)	Tension lbs. (kN)	Shear lbs. (kN)	Tension lbs. (kN)	Shear lbs. (kN)
3/16	1-3/4 (44.4)	1,240 (5.5)	985 (4.4)	1,310 (5.8)	985 (4.4)	1,430 (6.4)	985 (4.4)	1,615 (7.2)	985 (4.4)	1,760 (7.8)	985 (4.4)
1/4	1-3/4 (44.4)	1,855 (8.3)	1,500 (6.7)	1,995 (8.9)	1,500 (6.7)	2,235 (10.0)	1,500 (6.7)	2,630 (11.7)	1,500 (6.7)	2,995 (13.3)	1,500 (6.7)
5/16	1-3/4 (49.2)	2,520 (11.2)	2,000 (8.9)	2,760 (12.3)	2,000 (8.9)	3,185 (14.2)	2,720 (12.1)	3,350 (14.9)	2,720 (12.1)	3,625 (16.1)	2,720 (12.1)
	2-1/2 (63.5)	3,365 (15.0)	2,000 (8.9)	3,625 (16.1)	2,000 (8.9)	3,625 (16.1)	2,720 (12.1)	3,625 (16.1)	2,720 (12.1)	3,625 (16.1)	2,720 (12.1)
	3 (76.2)	3,780 (16.8)	2,000 (8.9)	3,780 (16.8)	2,000 (8.9)	3,780 (16.8)	2,720 (12.1)	3,780 (16.8)	2,720 (12.1)	3,780 (16.8)	2,720 (12.1)

1. Tabulated load values are for anchors installed in concrete. Concrete compressive strength must be at the specified minimum at the time of installation.
2. Ultimate load capacities must be reduced by a minimum safety factor of 4.0 or greater to determine allowable working load.

Allowable Load Capacities for Tapper+ in Normal-Weight Concrete^{1,2,3}

Nominal Anchor Diameter d in.	Minimum Embedment Depth in. (mm)	Minimum Concrete Compressive Strength									
		f'c = 2,500 psi (17.3 MPa)		f'c = 3,000 psi (20.7 MPa)		f'c = 4,000 psi (27.6 MPa)		f'c = 6,000 psi (41.4 MPa)		f'c = 8,000 psi (55.2 MPa)	
		Tension lbs. (kN)	Shear lbs. (kN)	Tension lbs. (kN)	Shear lbs. (kN)	Tension lbs. (kN)	Shear lbs. (kN)	Tension lbs. (kN)	Shear lbs. (kN)	Tension lbs. (kN)	Shear lbs. (kN)
3/16	1-3/4 (44.4)	310 (1.4)	245 (1.1)	325 (1.4)	245 (1.1)	360 (1.6)	245 (1.1)	400 (1.8)	245 (1.1)	440 (2.0)	245 (1.1)
1/4	1-3/4 (44.4)	460 (2.0)	375 (1.7)	495 (2.2)	375 (1.7)	555 (2.5)	375 (1.7)	655 (2.9)	375 (1.7)	750 (3.3)	375 (1.7)
5/16	1-3/4 (49.2)	630 (2.8)	500 (2.2)	690 (3.1)	500 (2.2)	795 (3.5)	680 (3.0)	840 (3.7)	680 (3.0)	905 (4.0)	680 (3.0)
	2-1/2 (63.5)	840 (3.7)	500 (2.2)	905 (4.0)	500 (2.2)	905 (4.0)	680 (3.0)	905 (4.0)	680 (3.0)	905 (4.0)	680 (3.0)
	3 (76.2)	945 (4.2)	500 (2.2)	945 (4.2)	500 (2.2)	945 (4.2)	680 (3.0)	945 (4.2)	680 (3.0)	945 (4.2)	680 (3.0)

1. Allowable load capacities listed are calculated using and applied safety factor of 4.0. Consideration of safety factors of 10 or higher may be necessary depending on the application, such as life safety or overhead.
2. Linear interpolation may be used to determine allowable loads for intermediate compressive strengths.
3. Allowable load capacities are multiplied by reduction factors found when anchor spacing or edge distances are less than critical distances.

ALLOWABLE STRESS DESIGN (ASD) DESIGN CRITERIA



Spacing Reduction Factors -Tension (F_{NS})

Diameter (in)	3/16	1/4	5/16
Critical Spacing S_{cr} (in)	3.69	3.69	3.30
Minimum Spacing s_{min} (in)	1	2	2
Min. Slab Thickness h_{min} (in)	3-1/4	3-1/4	3-1/4
Minimum Embedment h_v (in)	1-3/4	1-3/4	1-7/8
Spacing Distance (inches)	3/4	-	-
	1	0.68	-
	1-1/4	0.71	-
	1-1/2	0.74	-
	1-3/4	0.77	-
	2	0.80	0.80
	2-1/4	0.83	0.83
	2-1/2	0.86	0.86
	2-3/4	0.89	0.89
	3	0.92	0.92
	3-1/2	0.98	0.98
	4	1.00	1.00

Edge Distance Reduction Factors- Tension (F_{NC})

Diameter (in)	3/16	1/4	5/16
Critical Edge Distance c_{cr} (in)	3	3	2-1/2
Minimum Edge Distance c_{min} (in)	1-3/4	1-3/4	1-1/2
Min. Slab Thickness h_{min} (in)	3-1/4	3-1/4	3-1/4
Minimum Embedment h_v (in)	1-3/4	1-3/4	1-7/8
Edge Distance (inches)	1-1/4	-	-
	1-1/2	-	0.60
	1-3/4	0.58	0.58
	2	0.67	0.67
	2-1/4	0.75	0.75
	2-1/2	0.83	0.83
	2-3/4	0.92	0.92
	3	1.00	1.00

Spacing Reduction Factors -Shear (F_{VS})

Diameter (in)	3/16	1/4	5/16
Critical Spacing S_{cr} (in)	3.69	3.69	3.30
Minimum Spacing s_{min} (in)	1	2	2
Min. Slab Thickness h_{min} (in)	3-1/4	3-1/4	3-1/4
Minimum Embedment h_v (in)	1-3/4	1-3/4	1-7/8
Spacing Distance (inches)	3/4	-	-
	1	0.79	-
	1-1/4	0.81	-
	1-1/2	0.83	-
	1-3/4	0.85	-
	2	0.87	0.87
	2-1/4	0.89	0.89
	2-1/2	0.91	0.91
	2-3/4	0.93	0.93
	3	0.95	0.95
	3-1/2	0.99	0.99
	4	1.00	1.00

Edge Distance Reduction Factors -Shear (F_{VC})

Diameter (in)	3/16	1/4	5/16
Critical Edge Distance c_{cr} (in)	3.7	3.7	3.3
Minimum Edge Distance c_{min} (in)	1-3/4	1-3/4	1-1/2
Min. Slab Thickness h_{min} (in)	3-1/4	3-1/4	3-1/4
Minimum Embedment h_v (in)	1-3/4	1-3/4	1-7/8
Edge Distance (inches)	1-1/4	-	-
	1-1/2	-	0.45
	1-3/4	0.47	0.47
	2	0.54	0.54
	2-1/4	0.61	0.61
	2-1/2	0.68	0.68
	2-3/4	0.75	0.75
	3	0.81	0.81
	3-1/2	0.95	0.95
	4	1.00	1.00

MASONRY PERFORMANCE DATA

Ultimate and Allowable Load Capacities for Tapper+ Anchors Installed into the Face of Hollow Concrete Masonry^{1,2,3}



Nominal Anchor Diameter <i>d</i> in.	Minimum Embed. <i>h_v</i> in. (mm)	Minimum Edge Distance in. (mm)	Minimum End Distance in. (mm)	ASTM C-90 Block Type	Ultimate Loads		Allowable Loads	
					Tension lbs (kN)	Shear lbs (kN)	Tension lbs (kN)	Shear lbs (kN)
3/16	1 (25.4)	2 (50.8)	2 (50.8)	Lightweight ⁴	340 (1.5)	460 (2.1)	65 (0.3)	90 (0.4)
	1 (25.4)	3 (76.2)	3 (76.2)	Lightweight ⁴	440 (2.0)	670 (3.0)	90 (0.4)	135 (0.6)
	1-1/4 (31.8)	2 (50.8)	2 (50.8)	Normal Weight ⁵	575 (2.6)	700 (3.1)	115 (0.5)	140 (0.6)
1/4	1 (25.4)	2 (50.8)	2 (50.8)	Lightweight ⁴	495 (2.2)	530 (2.4)	100 (0.4)	90 (0.4)
	1 (25.4)	3 (76.2)	3 (76.2)	Lightweight ⁴	580 (2.6)	820 (3.6)	115 (0.5)	165 (0.7)
	1-1/4 (31.8)	2 (50.8)	2 (50.8)	Normal Weight ⁶	950 (4.2)	740 (3.3)	190 (0.8)	150 (0.7)
5/16	1-1/4 (31.8)	2 (50.8)	2 (50.8)	Lightweight ^{7,8}	930 (4.1)	1,290 (5.7)	185 (0.8)	260 (1.2)
		2 (50.8)	2 (50.8)	Normal Weight ⁷	1,005 (4.5)	1,035 (4.6)	200 (0.9)	205 (0.9)

1. Tabulated load values are for anchors installed in minimum 8" wide, Grade N, Type II, light weight or normal weight concrete masonry units conforming to ASTM C 90 that have reached the minimum designated ultimate compressive strength at the time of installation ($f'm \geq 1,700$ psi).
2. Allowable load capacities listed are calculated using an applied safety factor of 5.0. Consideration of safety factors of 10 or higher may be necessary depending on the application, such as life safety or overhead.
3. Allowable shear loads into the face shell of a masonry wall may be applied in any direction.
4. The tabulated values for the 3/16-inch and 1/4-inch diameter Tapper+ in light weight block are applicable for anchors installed at a critical spacing between anchors of 16 times the anchor diameter. The anchors may be reduced to a minimum spacing distance of 8 times the anchor diameter provided the allowable tension loads are reduced by 12 percent. Allowable shear loads do not need to be reduced.
5. The tabulated values for the 3/16-inch diameter Tapper+ in normal weight block are applicable for anchors installed at a critical spacing between anchors of 8 times the anchor diameter.
6. The tabulated values for the 1/4-inch Tapper+ in normal weight block are applicable for anchors installed at a critical spacing between anchors of 16 times the anchor diameter. The anchors may be reduced to a minimum spacing distance of 8 times the anchor diameter provided the allowable tension loads are reduced by 20 percent. Allowable shear loads do not need to be reduced.
7. The tabulated values for the 5/16-inch Tapper+ in lightweight and normal weight block are applicable for anchors installed at a critical spacing between anchors of 16 times the anchor diameter.
8. The tabulated tension value for the 5/16" Tapper+ in lightweight block may be increased by 30% if drilling method is rotation only.

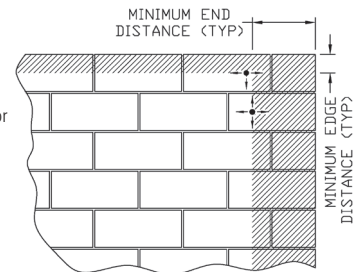

Ultimate and Allowable Load Capacities for Tapper+ Anchors Installed into the Face of Grout Filled Concrete Masonry^{1,2,3,4}

Nominal Anchor Diameter <i>d</i> in.	Minimum Embed. <i>h_v</i> in. (mm)	Minimum Edge Distance in. (mm)	Minimum End Distance in. (mm)	Installation Location	ASTM C-90 Block Type	Ultimate Loads		Allowable Loads	
						Tension lbs. (kN)	Shear lbs. (kN)	Tension lbs. (kN)	Shear lbs. (kN)
3/16	1-1/2 (38.1)	8 (203.2)	3 (76.2)	Mortar	Lightweight	625 (2.8)	660 (2.9)	125 (0.6)	130 (0.6)
		3 (76.2)	3 (76.2)	Face	Lightweight	410 (1.8)	600 (2.7)	80 (0.4)	120 (0.5)
1/4	1-1/2 (38.1)	8 (203.2)	3 (76.2)	Mortar	Lightweight	730 (3.3)	1,010 (4.5)	145 (0.7)	200 (0.9)
		3 (76.2)	3 (76.2)	Face	Lightweight	650 (2.9)	1,010 (4.5)	130 (0.6)	200 (0.9)
5/16	2-1/2 (6.35)	8 (203.2)	4 (101.6)	Mortar	Lightweight	1,640 (7.3)	2,190 (9.7)	330 (1.5)	440 (2.0)
		4 (101.6)	4 (101.6)	Face	Lightweight	2,110 (9.4)	1,900 (8.5)	420 (1.9)	380 (1.7)

1. Tabulated load values are for 3/16-inch and 1/4-inch anchors installed in minimum 6" wide, Grade N, Type II, light weight concrete masonry units conforming to ASTM C 90 that have reached the minimum designated ultimate compressive strength at the time of installation ($f'm \geq 1,500$ psi).
2. Tabulated load values are for 5/16-inch anchors installed in minimum 8" wide, Grade N, Type II, light weight concrete masonry units conforming to ASTM C 90 that have reached the minimum designated ultimate compressive strength at the time of installation ($f'm \geq 1,500$ psi).
3. Allowable load capacities listed are calculated using an applied safety factor of 5.0. Consideration of safety factors of 10 or higher may be necessary depending on the application, such as life safety or overhead.
4. Allowable shear loads into the face shell of a masonry wall may be applied in any direction.

MASONRY PERFORMANCE DATA



MECHANICAL ANCHORS

Ultimate and Allowable Load Capacities for Tapper+ Anchors Installed into the Tops of Grout Filled Concrete Masonry Walls^{1,2,3}

Nominal Anchor Diameter <i>d</i> in.	Minimum Embed. <i>h_v</i> in. (mm)	Minimum Edge Distance in. (mm)	Minimum End Distance in. (mm)	ASTM C-90 Block Type	Ultimate Loads		Allowable Loads	
					Tension lbs (kN)	Shear lbs (kN)	Tension lbs (kN)	Shear lbs (kN)
3/16	1.5 (38.1)	1.5 (38.1)	3 (76.2)	Lightweight	450 (2.0)	510 (2.3)	90 (0.4)	100 (0.5)
1/4	1.5 (38.1)	1.5 (38.1)	3 (76.2)	Lightweight	825 (3.7)	780 (3.5)	165 (0.7)	155 (0.7)
5/16	2 (50.8)	1.75 (44.5)	3 (76.2)	Lightweight	1,735 (7.7)	800 (3.6)	350 (1.5)	160 (0.7)

1. Tabulated load values are for 3/16-inch and 1/4-inch anchors installed in minimum 6" wide, Grade N, Type II, light weight concrete masonry units conforming to ASTM C 90 that have reached the minimum designated ultimate compressive strength at the time of installation ($f'm \geq 1,500$ psi).
2. Tabulated load values are for 5/16-inch anchors installed in minimum 8" wide, Grade N, Type II, light weight concrete masonry units conforming to ASTM C 90 that have reached the minimum designated ultimate compressive strength at the time of installation ($f'm \geq 1,500$ psi).
3. Allowable load capacities listed are calculated using an applied safety factor of 5.0. Consideration of safety factors of 10 or higher may be necessary depending on the application, such as life safety or overhead.

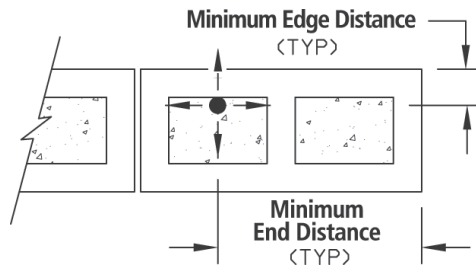

PERFORMANCE DATA



Allowable Load Capacities for Tapper+ Anchors Installed in Clay Brick Masonry^{1,2,3,4}

Nominal Anchor Diameter <i>d</i> in.	Minimum Embed. <i>h_v</i> in. (mm)	Minimum Edge Distance in. (mm)	Minimum End Distance in. (mm)	Installation Location	Tension lbs. (kN)	Shear lbs. (kN)
3/16	1-1/2 (38.1)	1-3/4 (44.5)	1-3/4 (44.5)	Face	380 (1.7)	165 (0.7)
				Mortar Joint	300 (1.3)	190 (0.8)
1/4				Face	605 (2.7)	270 (1.2)
				Mortar Joint	200 (0.9)	155 (0.7)

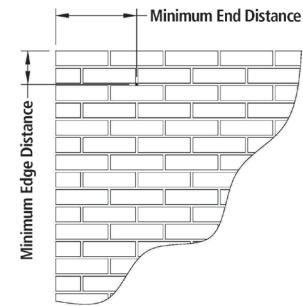

1. Tabulated load values are for anchors installed in multiple wythe, minimum Grade SW, solid clay brick masonry walls conforming to ASTM C 62. Mortar must be minimum Type N. Masonry compressive strength must be at the specified minimum at the time of installation ($f'm \geq 1,500$ psi).
2. Allowable load capacities listed are calculated using and applied safety factor of 5.0. Consideration of safety factors of 10 or higher may be necessary depending upon the application such as lifesafety or overhead.
3. Allowable shear loads into the face or mortar joint of the brick masonry wall may be applied in any direction.
4. The tabulated values are applicable for anchors installed at a critical spacing between anchors of 12 times the anchor diameter.

Average Withdrawal Capacity and Average Bending Yield Moment of Tapper+ in Wood¹

Nominal Anchor Diameter <i>d</i> in.	Minimum Embed. <i>h_v</i> in. (mm)	Minimum Edge Distance in. (mm)	Withdrawal Capacity ¹ lbs. (kN)	Bending Yield Moment psi (MPa)
3/16	1 (25.4)	1-3/4 (44.5)	540 (2.4)	67,000 (464)
	1-1/2 (38.1)	1-3/4 (44.5)	820 (3.7)	67,000 (464)
1/4	1 (25.4)	1-3/4 (44.5)	680 (3.0)	107,000 (740)
	1-1/2 (38.1)	1-3/4 (44.5)	1,050 (4.7)	107,000 (740)

1. Tests in Douglas-Fir Larch with Specific Gravity of 0.42; screw oriented tangential to wood grain.

INSTALLATION SPECIFICATIONS



Strength Design Installation Table for Tapper+¹

Anchor Property/Setting Information	Notation	Units	3/16	1/4	5/16
Nominal outside anchor diameter	d_a	in. (mm)	0.145 (3.7)	0.185 (4.7)	0.250 (6.4)
Nominal drill bit diameter	d_{bit}	in. (mm)	3/16 Tapper+ Bit	1/4 Tapper+ Bit	5/16 Tapper+ Bit
Tapper+ bit tolerance range	-	in.	0.170 to 0.176	0.202 to 0.207	0.255 to 0.259
Minimum nominal embedment depth	h_{nom}	in. (mm)	1-3/4 (44)	1-3/4 (44)	1-7/8 (48)
Effective embedment	h_{ef}	in. (mm)	1.23 (31)	1.23 (31)	1.10 (76)
Minimum hole depth	h_{hole}	in. (mm)	2 (51)	2 (51)	2-1/4 (57)
Minimum concrete member thickness	h_{min}	in. (mm)	3-1/4 (83)	3-1/4 (83)	3-1/4 (83)
Minimum overall anchor length	ℓ_{anch}	in. (mm)	2-1/4 (57)	2-1/4 (57)	2 (51)
Minimum edge distance	c_{min}	in. (mm)	1-3/4 (44)	1-3/4 (44)	1-1/2 (38)
Minimum spacing distance	s_{min}	in. (mm)	1 (25)	2 (51)	2 (51)
Critical edge distance	c_{ac}	in. (mm)	3 (76)	3 (76)	2-1/2 (64)
Max impact wrench power	T_{screw}	ft-lbs (N-m)	-	-	115 (150)
Phillips bit size (No.)	-	-	2	3	3

For SI: 1 inch = 25.4 mm, 1 ft-lbf = 1.356 N-m.

1. The Information presented in this table is to be used in conjunction with the design criteria of ACI 318 Appendix D.

Tapper+ Anchor Detail

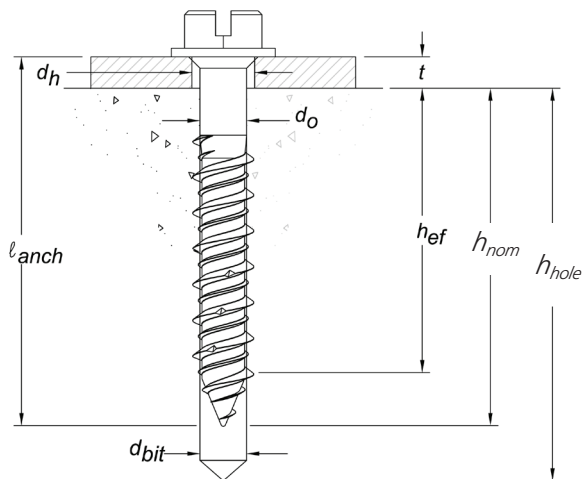

Slotted hex head version pictured, flat head length is measured from top of head to tip of anchor.

STRENGTH DESIGN INFORMATION
**Tension Design Information for Tapper+ Anchor in Concrete
(For Use with Load Combinations Taken from ACI 318, Section 9.2)^{1,2,3,4,5,6,7,8,9}**

Design Characteristic	Notation	Units	Nominal Anchor Size (Inch)		
			3/16	1/4	5/16
Anchor category	1,2 or 3	-	1	1	1
Nominal embedment depth	h_{nom}	in. (mm)	1-3/4 (44)	1-3/4 (44)	1-7/8 (48)
STEEL STRENGTH IN TENSION⁴					
Minimum specified ultimate tensile strength (neck)	f_{uta}^8	ksi (N/mm ²)	100 (689)	100 (689)	100 (689)
Effective tensile stress area (neck)	A_{se}, N (A_{se}) ⁹	in ² (mm ²)	0.0162 (10.4)	0.0268 (17.3)	0.044 (28.4)
Steel strength in tension	N_{sa}^8	lb (kN)	1,620 (7.2)	2,680 (12.0)	4,400 (19.6)
Reduction factor for steel strength ³	ϕ	-	0.65		
CONCRETE BREAKOUT STRENGTH IN TENSION⁷					
Effective embedment	h_{ef}	in. (mm)	1.23 (31.2)	1.23 (31.2)	1.10 (28)
Effectiveness factor for concrete breakout	k_{uncr}	-	24	24	24
Modification factor for cracked and uncracked concrete ⁵	$\Psi_{c,N}^9$	-	1.0 See note 5	1.0 See note 5	1.0 See note 5
Critical edge distance	c_{ac}	in. (mm)	3 (76.2)	3 (76.2)	2-1/2 (64)
Reduction factor for concrete breakout strength ³	ϕ	-	0.65 (Condition B)		
PULLOUT STRENGTH IN TENSION⁷					
Characteristic pullout strength, uncracked concrete (2,500 psi) ⁶	$N_{p,uncr}$	lb (kN)	635 (2.8)	940 (4.2)	See note 10
Reduction factor for pullout strength ³	ϕ	-	0.65 (Condition B)		

For SI: 1 inch = 25.4 mm, 1 ksi = 6.895 N/mm², 1 lbf = 0.0044 kN.

- The data in this table is intended to be used with the design provisions of ACI 318 Appendix D.
- Installation must comply with published instructions and details.
- All values of ϕ were determined from the load combinations of UBC Section 1605.2.1, UBC Section 1612.2.1, or ACI 318 Section 9.2. If the load combinations of UBC Section 1902.2 or ACI 318 Appendix C are used, the appropriate value of ϕ must be determined in accordance with ACI 318 D.4.5. For reinforcement that meets ACI 318 Appendix D requirements for Condition A, see ACI 318 D. 4.4 for the appropriate ϕ factor.
- The Tapper+ anchor is considered a brittle steel element as defined by ACI 318 D.1. Tabulated values for steel strength in tension must be used for design.
- For all design cases use $\Psi_{c,N} = 1.0$. The appropriate effectiveness factor for uncracked concrete (k_{uncr}) must be used.
- For all design cases use $\Psi_{c,p} = 1.0$. For calculation of N_{pn} , see Section 4.1.3 of this report.
- Anchors are permitted to be used in structural sand-lightweight provided that N_b , N_{eq} and N_{pn} are multiplied by a factor of 0.60.
- For 2003 IBC, f_{uta} replaces f_{ut} ; N_{sa} replaces N_s ; and $\Psi_{c,N}$ replaces Ψ_3 .
- The notation in parenthesis is for the 2006 IBC.
- Pullout strength does not control design of indicated anchors. Do not calculate pullout strength for indicated anchor size and embedment.

STRENGTH DESIGN INFORMATION

Shear Design Information for Tapper+ Anchor in Concrete
(For use with load combinations taken from ACI 318, Section 9.2)^{1,2,3,4,5,6,7,8}



Design Characteristic	Notation	Units	Nominal Anchor Diameter		
			3/16"	1/4"	5/16"
Anchor category	1, 2 or 3	-	1	1	1
Nominal embedment depth	h_{nom}	in. (mm)	1-3/4 (44)	1-3/4 (44)	1-7/8 (48)
STEEL STRENGTH IN SHEAR⁴					
Steel strength in shear ⁵	V_{sa}	lb (kN)	810 (3.6)	1,180 (5.3)	2,475 (11.1)
Reduction factor for steel strength ³	ϕ	-	0.60		
CONCRETE BREAKOUT STRENGTH IN SHEAR⁶					
Load bearing length of anchor (h_{ef} or $8d_o$, whichever is less)	ℓ_e	in. (mm)	1.23 (32)	1.23 (32)	1.10 (28)
Nominal anchor diameter	d_o (d_n)	in. (mm)	0.145 (3.7)	0.185 (4.7)	0.250 (6.4)
Reduction factor for concrete breakout ³	ϕ	-	0.70 (Condition B)		
PRYOUT STRENGTH IN SHEAR⁶					
Coefficient for prout strength (1.0 for $h_{ef} < 2.5$ in., 2.0 for $h_{ef} \geq 2.5$ in.)	k_{cp}	-	1.0	1.0	1.0
Effective embedment	h_{ef}	in. (mm)	1.23 (31.2)	1.23 (31.2)	1.10 (27.9)
Reduction factor for prout strength ³	ϕ	-	0.70 (Condition B)		

For SI: 1 inch = 25.4 mm, 1 lbf = 0.0044 kN.

- The data in this table is intended to be used with the design provisions of ACI 318 Appendix D.
- Installation must comply with published instructions and details.
- All values of ϕ were determined from the load combinations of UBC Section 1605.2.1, UBC Section 1612.2.1, or ACI 318 Section 9.2. If the load combinations of UBC Section 1902.2 or ACI 318 Appendix C are used, the appropriate value of ϕ must be determined in accordance with ACI 318 D.4.5. For reinforcement that meets ACI 318 Appendix D requirements for Condition A, see ACI 318 D.4.4 for the appropriate ϕ factor.
- The Tapper+ anchor is considered a brittle steel element as defined by ACI 318 D.1.
- Tabulated values for steel strength in shear must be used for design.
- Anchors are permitted to be used in structural sand-lightweight concrete, for ACI 318-05, the values V_b must be multiplied by 0.60, in lieu of ACI 318 D.3.4.
- For 2003 IBC, V_{sa} replaces V_s ; and ℓ_e replaces ℓ .
- The notation in parenthesis is for the 2006 IBC.

STRENGTH DESIGN PERFORMANCE DATA



Tension and Shear Design Strengths for Tapper+ in Uncracked Concrete

d	h _{nom}	2,500		3,000		4,000		6,000		8,000	
		φNn	φVn	φNn	φVn	φNn	φVn	φNn	φVn	φNn	φVn
3/16	1-3/4	415	485	435	485	475	485	540	485	585	485
1/4	1-3/4	610	710	660	710	740	710	870	710	975	710
5/16	1-7/8	900	970	985	1,060	1,140	1,225	1,395	1,485	1,610	1,485

Legend

Steel Strength Controls
 Concrete Breakout Strength Controls
 Anchor Pullout/Pryout Strength Controls

- Tabular values are provided for illustration and are applicable for single anchors installed in normal-weight concrete with minimum slab thickness, $h_a = h_{min}$, and with the following conditions:
 - c_{a1} is greater than or equal to the critical edge distance, c_{ac} (table values based on $c_{a1} = c_{a2}$).
 - c_{a2} is greater than or equal to $1.5 c_{a1}$.
- Calculations were performed according to ACI 318-08 Appendix D. The load level corresponding to the controlling failure mode is listed. (e.g. For tension: steel, concrete breakout and pullout; For shear: steel, concrete breakout and pryout). Furthermore, the capacities for concrete breakout strength in tension and pryout strength in shear are calculated using the effective embedment values, h_{ef} , for the selected anchors as noted in the design information tables. Please also reference the installation specifications for more information.
- Strength reduction factors (ϕ) were based on ACI 318 Section 9.2 for load combinations. Condition B is assumed.
- Tabular values are permitted for static loads only, seismic loading is not considered with these tables.
- For designs that include combined tension and shear, the interaction of tension and shear loads must be calculated in accordance with ACI 318 Appendix D.
- Interpolation is not permitted to be used with the tabular values. For intermediate base material compressive strengths please see ACI 318 Appendix D. For other design conditions including seismic considerations please see ACI 318 Appendix D.

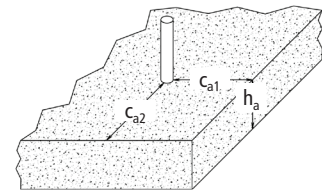

ORDERING INFORMATION



Blue Perma-Seal Tapper - Standard Pack*

Cat No.		Screw Size	Quantities	
HWH	PFH		Box	Carton
2700SD	2740SD	3/16" x 1-1/4"	100	500
2702SD	2742SD	3/16" x 1-3/4"	100	500
2704SD	2744SD	3/16" x 2-1/4"	100	500
2706SD	2746SD	3/16" x 2-3/4"	100	500
2708SD	2748SD	3/16" x 3-1/4"	100	500
2710SD	2750SD	3/16" x 3-3/4"	100	500
2712SD	2752SD	3/16" x 4"	100	500
2720SD	2760SD	1/4" x 1-1/4"	100	500
2722SD	2762SD	1/4" x 1-3/4"	100	500
2724SD	2764SD	1/4" x 2-1/4"	100	500
2726SD	2766SD	1/4" x 2-3/4"	100	500
2728SD	2768SD	1/4" x 3-1/4"	100	500
2730SD	2770SD	1/4" x 3-3/4"	100	500
2732SD	2772SD	1/4" x 4"	100	500
2734SD	2774SD	1/4" x 5"	100	100
2736SD	2776SD	1/4" x 6"	100	100

Blue Perma-Seal Tapper - Master Pack**

Cat No.		Screw Size	Quantities	Drill Bit References	
HWH	PFH			Straight	SDS Hex
9462SD	9476SD	3/16" x 1-1/4"	2000	2781	2793
9463SD	9477SD	3/16" x 1-3/4"	2000	2781	2793
9464SD	9478SD	3/16" x 2-1/4"	2000	2782	2793
9465SD	9479SD	3/16" x 2-3/4"	2000	2782	2793
9466SD	9480SD	3/16" x 3-1/4"	1000	2783	2794
9467SD	9481SD	3/16" x 3-3/4"	1000	2783	2794
9468SD	9482SD	3/16" x 4"	1000	2783	2794
9469SD	9483SD	1/4" x 1-1/4"	2000	2785	2796
9470SD	9484SD	1/4" x 1-3/4"	2000	2785	2796
9471SD	9485SD	1/4" x 2-1/4"	1000	2786	2796
9472SD	9486SD	1/4" x 2-3/4"	1000	2786	2796
9473SD	9487SD	1/4" x 3-1/4"	1000	2787	2797
9474SD	9488SD	1/4" x 3-3/4"	1000	2787	2797
9475SD	9489SD	1/4" x 4"	1000	2787	2797
	9490SD	1/4" x 5"	1000	2788	2797
	9491SD	1/4" x 6"	1000	2789	2797

HWH = Hex Washer Head (slotted) ; PFH = Phillips Flat Head ; TFH = Trim Flat Head ; FHH = Flange Hex Head.

Tapper+ parts have an "SD" designation added to the catalog number.

* - One Tapper+ drill bit included in each standard box.

** - Drill bit not included with master pack.

Shaded catalog numbers denote sizes which are less than the minimum standard anchor length for strength design.



Carbide Drill Bits for Perma-Seal TAPPER+ - Straight Shank

Cat. No.	Size	Usable Length	Std. Tube	Wt./ 10
2781SD	5/32" x 3-1/2"	2	10	1/4
2782SD	5/32" x 4-1/2"	3	10	1/4
2783SD	5/32" x 5-1/2"	4	10	1/4
2785SD	3/16" x 3-1/2"	2	10	1/4
2786SD	3/16" x 4-1/2"	3	10	1/4
2787SD	3/16" x 5-1/2"	4	10	1/2
2788SD	3/16" x 6-1/2"	5	10	1/2
2789SD	3/16" x 7-1/2"	6	10	1/2



Carbide Drill Bits for Perma-Seal TAPPER+ - Hex Shank SDS-Plus

Cat. No.	Size	Usable Length	Std. Tube	Wt./ 10
2793SD	5/32" x 5"	3	1	1
2794SD	5/32" x 7"	5	1	1
2796SD	3/16" x 5"	3	1	1
2797SD	3/16" x 7"	5	1	1

ACCESSORIES



Installation Tools for 3/16" and 1/4" TAPPER+

Cat. No.	Description	Max Screw Length	Max Bit Length	Std. Box	Wt./ Each
2791	*Combo TAPPER 1000 Tool	4"	5-1/2"	1	3/4
2795	1000 SDS Extension (8")	6"	7-1/2"	1	1/2

* This tool cannot be used with SDS Drill Bits or PFH screws.

ORDERING INFORMATION

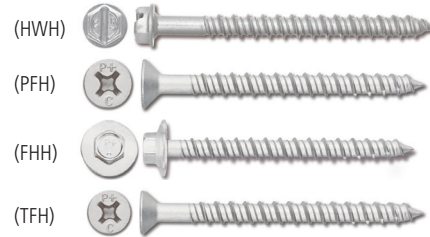
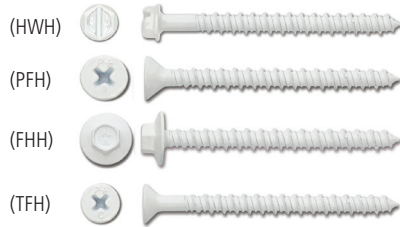

White Perma-Seal Tapper+ - Standard Pack*

Cat No.				Screw Size	Quantities	
HWH	PFH	FHH	TFH		Box	Carton
2400SD	2440SD			3/16" x 1-1/4"	100	500
2402SD	2442SD			3/16" x 1-3/4"	100	500
2404SD	2444SD			3/16" x 2-1/4"	100	500
2406SD	2446SD			3/16" x 2-3/4"	100	500
2408SD	2448SD			3/16" x 3-1/4"	100	500
2410SD	2450SD			3/16" x 3-3/4"	100	500
2412SD	2449SD			3/16" x 4"	100	500
2420SD	2460SD			1/4" x 1-1/4"	100	500
2422SD	2462SD	8706SD	8710SD	1/4" x 1-3/4"	100	500
2424SD	2464SD	8707SD	8711SD	1/4" x 2-1/4"	100	500
2426SD	2466SD	8708SD	8712SD	1/4" x 2-3/4"	100	500
2428SD	2468SD	8709SD	8713SD	1/4" x 3-1/4"	100	500
2430SD	2470SD		8714SD	1/4" x 3-3/4"	100	500
2435SD	2472SD			1/4" x 4"	100	500

Silver Perma-Seal Tapper - Standard Pack*

Cat No.				Screw Size	Quantities	
HWH	PFH	FHH	TFH		Box	Carton
	2498SD			3/16" x 1-1/4"	100	500
	2500SD			3/16" x 1-3/4"	100	500
	2501SD			3/16" x 2-1/4"	100	500
	2502SD			3/16" x 2-3/4"	100	500
	2503SD			3/16" x 3-1/4"	100	500
	2504SD			3/16" x 3-3/4"	100	500
	2505SD			3/16" x 4"	100	500
2486SD	2506SD			1/4" x 1-1/4"	100	500
2488SD	2507SD	8715SD	8719SD	1/4" x 1-3/4"	100	500
2490SD	2508SD	8716SD	8720SD	1/4" x 2-1/4"	100	500
2492SD	2509SD	8717SD	8721SD	1/4" x 2-3/4"	100	500
2494SD	2510SD	8718SD	8722SD	1/4" x 3-1/4"	100	500
2495SD	2511SD		8723SD	1/4" x 3-3/4"	100	500
2496SD	2512SD			1/4" x 4"	100	500

White Perma-Seal Tapper+ - Master Pack**

Cat No.		Screw Size	Quantities	Drill Bit References	
HWH	PFH			Straight	SDS Hex
	9191SD	3/16" x 1-1/4"	2000	2781	2793
	9192SD	3/16" x 1-3/4"	2000	2781	2793
	9193SD	3/16" x 2-1/4"	2000	2782	2793
	9194SD	3/16" x 2-3/4"	2000	2782	2793
	9195SD	3/16" x 3-1/4"	1000	2783	2794
	9196SD	3/16" x 3-3/4"	1000	2783	2794
	9197SD	3/16" x 4"	1000	2783	2794
9923SD	9951SD	1/4" x 1-1/4"	2000	2785	2796
9924SD	9952SD	1/4" x 1-3/4"	2000	2785	2796
9925SD	9953SD	1/4" x 2-1/4"	1000	2786	2796
9926SD	9954SD	1/4" x 2-3/4"	1000	2786	2796
9927SD	9955SD	1/4" x 3-1/4"	1000	2787	2797
9928SD	9956SD	1/4" x 3-3/4"	1000	2787	2797
9929SD	9957SD	1/4" x 4"	1000	2787	2797

Silver Perma-Seal Tapper - Master Pack**

Cat No.		Screw Size	Quantities	Drill Bit References	
HWH	PFH			Straight	SDS Hex
	8757SD	3/16" x 1-1/4"	2000	2781	2793
	8758SD	3/16" x 1-3/4"	2000	2781	2793
	8759SD	3/16" x 2-1/4"	2000	2782	2793
	8760SD	3/16" x 2-3/4"	2000	2782	2793
	8761SD	3/16" x 3-1/4"	1000	2783	2794
	8762SD	3/16" x 3-3/4"	1000	2783	2794
	8763SD	3/16" x 4"	1000	2783	2794
8750SD	8764SD	1/4" x 1-1/4"	2000	2785	2796
8751SD	8765SD	1/4" x 1-3/4"	2000	2785	2796
8752SD	8766SD	1/4" x 2-1/4"	1000	2786	2796
8753SD	8767SD	1/4" x 2-3/4"	1000	2786	2796
8754SD	8768SD	1/4" x 3-1/4"	1000	2787	2797
8755SD	8769SD	1/4" x 3-3/4"	1000	2787	2797
8756SD	8770SD	1/4" x 4"	1000	2787	2797

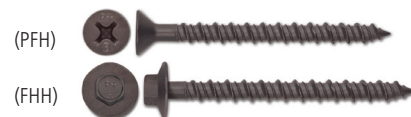

Bronze Perma-Seal Tapper - Standard Pack*

Cat No.		Screw Size	Quantities	
PFH	FHH		Box	Carton
9975SD	9977SD	1/4" x 1-3/4"	100	500
9976SD	9978SD	1/4" x 2-1/4"	100	500

Shaded catalog numbers denote sizes which are less than the minimum standard anchor length for strength design.
Flange Hex Head parts are not included in the scope of ESR-3068

ORDERING INFORMATION

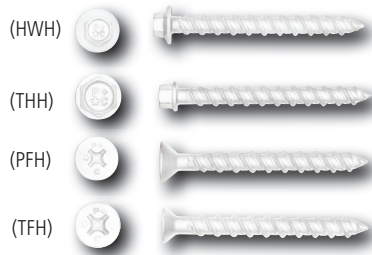

White Perma-Seal Tapper+ Xtreme

Standard Pack*						
Cat No.				Screw Size	Quantity	
HWH	THH	PFH	TFH		Box	Carton
2300SD	2330SD		2340SD	5/16" x 1-3/4"	100	500
2302SD	2332SD	2312SD	2342SD	5/16" x 2-1/4"	100	500
2304SD	2334SD	2314SD	2344SD	5/16" x 2-3/4"	100	500
2306SD	2316SD	2316SD	2346SD	5/16" x 3-1/4"	100	500
2308SD	2318SD	2318SD	2348SD	5/16" x 4"	100	500
2310SD		2320SD	2350SD	5/16" x 5"	100	500
		2322SD		5/16" x 6"	100	500

Silver Perma-Seal Tapper+ Xtreme

Standard Pack*						
Cat No.				Screw Size	Quantity	
HWH	THH	PFH	TFH		Box	Carton
2200SD	2230SD		2240SD	5/16" x 1-3/4"	100	500
2202SD	2232SD	2212SD	2242SD	5/16" x 2-1/4"	100	500
2204SD	2234SD	2214SD	2244SD	5/16" x 2-3/4"	100	500
2206SD	2236SD	2216SD	2246SD	5/16" x 3-1/4"	100	500
2208SD	2238SD	2218SD	2248SD	5/16" x 4"	100	500
2210SD		2220SD	2250SD	5/16" x 5"	100	500
		2222SD		5/16" x 6"	100	500



Installation Tools for Tapper+ Xtreme

Cat. No.	Description	Std. Box	Wt./ Each
2291SD	Tapper+ Xtreme Installation Kit includes: #3 Phillips Impact Power Bit 5/16" Impact Ready Nut Driver 1/4" x 6" SDS+ Tapper+ /Wedge Bit 1/4" x 8" Wedge Bit SDS+	1	3/4

White and bronze Perma-Seal® finishes available by special order.

Bronze Perma-Seal Tapper+ Xtreme

Standard Pack*						
Cat No.				Screw Size	Quantity	
HWH	THH	PFH	TFH		Box	Carton
2600SD	2630SD		2640SD	5/16" x 1-3/4"	100	500
2602SD	2632SD	2612SD	2642SD	5/16" x 2-1/4"	100	500
2604SD	2634SD	2614SD	2644SD	5/16" x 2-3/4"	100	500
2606SD	2636SD	2616SD	2646SD	5/16" x 3-1/4"	100	500
2608SD	2638SD	2618SD	2648SD	5/16" x 4"	100	500
2610SD		2620SD	2650SD	5/16" x 5"	100	500
		2622SD		5/16" x 6"	100	500

Carbide Drill Bits for 5/16" Perma-Seal Tapper+ SDS-Plus

Cat No.	Size	Useable Length	Std. Tube	Wt./10
01314	5/16" x 6"	4"	1	1
01315	5/16" x 8"	6"	1	1

* - One Tapper+ Drill Bit included in each standard box