

Power-Stud™ HD5 Hot-Dip Galvanized Wedge Expansion Anchor

PRODUCT DESCRIPTION

The Power-Stud HD5 anchor is a fully threaded, torque-controlled, wedge expansion anchor. Suitable base materials include normal-weight concrete and structural sand-lightweight concrete. The anchor is manufactured with a hot-dip galvanized carbon steel body and stainless steel expansion clip. Nut and washer are included.

GENERAL APPLICATIONS AND USES

- Racking and Shelving
- Support Ledgers
- Fencing
- Maintenance
- Material Handling
- Storage Facilities
- Repairs
- Retrofits

FEATURES AND BENEFITS

- + Consistent performance in high and low strength concrete
- + Nominal drill bit size is the same as the anchor diameter
- + Anchor can be installed through standard fixture holes
- + Length ID code and identifying marking stamped on head of each anchor

GUIDE SPECIFICATIONS

CSI Divisions: 03 16 00 - Concrete Anchors, 04 05 19.16 - Masonry Anchors and 05 05 19 Post - Installed Concrete Anchors. Expansion Anchors shall be Power-Stud HD5 as supplied by Powers Fasteners, Inc., Brewster, NY. Anchors shall be installed in accordance with published instructions and the Authority Having Jurisdiction.

MATERIAL SPECIFICATIONS

Anchor Component	Specification
Anchor body	Medium carbon steel
Hex Nut	Carbon steel, ASTM A 563, Grade A
Washer	Carbon steel ASTM F 844; meets dimensional requirements of ANSI B18.22.2, Type A plain
Expansion wedge (clip)	Type 304 Stainless Steel
Plating (Anchor, body, nut, washer)	Zinc Galvanized According to ASTM A 153 Class C or D

SECTION CONTENTS Page No.

General Information 1

Material Specifications 1

Installation Instructions 2

ASD Installation Specifications 3

ASD Performance Data 4

Masonry Performance Data 8

Ordering Information 9

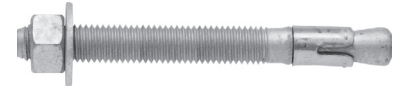

Power-Stud HD5 Assembly

THREAD VERSION

UNC Threaded Stud

ANCHOR MATERIALS

Hot-dipped galvanized carbon steel body, stainless steel expansion clip, hot-dip galvanized nut and washer

ROD/ANCHOR SIZE RANGE (TYP.)

3/8" diameter through 3/4" diameter

SUITABLE BASE MATERIALS

Normal-weight concrete
Structural sand-lightweight concrete
Grouted concrete masonry

MATERIAL SPECIFICATIONS

Installation Instruction for Power-Stud™ HD5

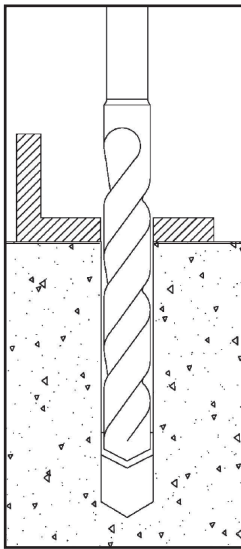

1.) Using the proper drill bit size, drill a hole into the base material to the required depth. The tolerances of the drill bit used should meet the requirements of ANSI Standard B212.15.

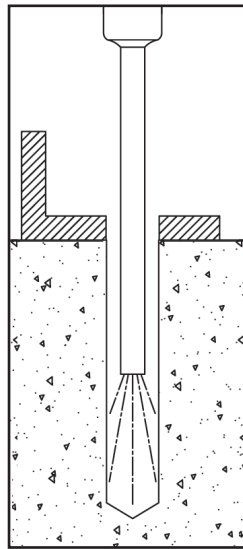

2.) Remove dust and debris from the hole using a hand pump, compressed air or a vacuum.

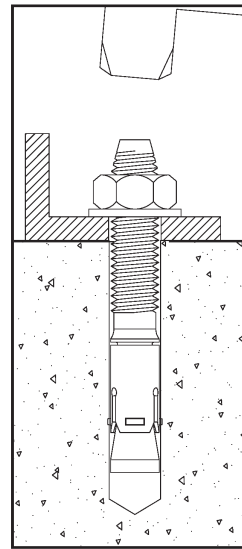

3.) Position the washer on the anchor and thread on the nut. If installing through a fixture, drive the anchor through the fixture into the hole. Be sure the anchor is driven to the minimum required embedment depth, h_v .

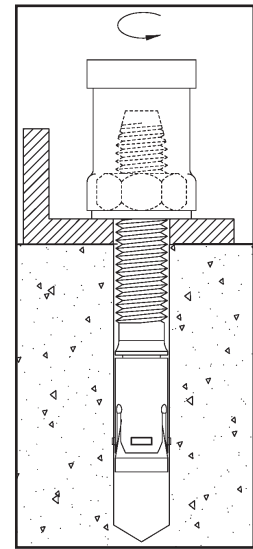

4.) Tighten the anchor with a torque wrench by applying the required installation torque, T_{inst} .

ANCHOR SPECIFICATIONS

Power-Stud HD5 Anchor Detail

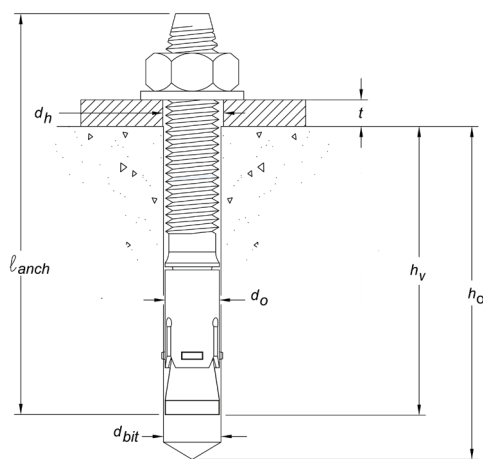

Length Identification

Mark	A	B	C	D	E	F	G	H	I	J	K	L	M	N	O
From	1-1/2"	2"	2-1/2"	3"	3-1/2"	4"	4-1/2"	5"	5-1/2"	6"	6-1/2"	7"	7-1/2"	8"	8-1/2"
Up to but not including	2"	2-1/2"	3"	3-1/2"	4"	4-1/2"	5"	5-1/2"	6"	6-1/2"	7"	7-1/2"	8"	8-1/2"	9"

Length identification mark indicates overall length of anchor.

INSTALLATION SPECIFICATIONS

Installation Table for Power-Stud™ HD5

Anchor Property/ Setting Information	Notation	Units	Nominal Anchor Diameter (inch)									
			3/8		1/2		5/8			3/4		
Anchor outside diameter	d	in. (mm)	0.375 (9.525)		0.500 (12.7)		0.625 (15.9)			0.750 (19.05)		
Minimum diameter of hole clearance in fixture	d_h	in. (mm)	7/16 (11.1)		9/16 (14.3)		11/16 (17.5)			13/16 (20.6)		
Nominal drill bit diameter	d_{bit}	in. (mm)	3/8 ANSI		1/2 ANSI		5/8 ANSI			3/4 ANSI		
Minimum nominal embedment depth	h_v	in. (mm)	1-3/4 (44)	2-3/8 (60)	2 (51)	2-1/2 (64)	3-3/4 (95)	2-3/8 (60)	3-3/8 (86)	4-5/8 (117)	3-3/8 (66)	5 (127)
Minimum hole depth	h_o	in. (mm)	2 (51)	2-5/8 (67)	2-1/2 (64)	3 (76)	4-1/4 (108)	2-7/8 (73)	3-7/8 (98)	5-1/8 (130)	3-7/8 (98)	5-1/2 (140)
Minimum member thickness	h_{min}	in. (mm)	3-1/4 (83)	4 (102)	4 (102)	5 (127)	6 (152)	5 (127)	6 (152)	7 (178)	6 (152)	10 (254)
Minimum overall anchor length ¹	l_{anch}	in. (mm)	3 (76)	3 (76)	2-3/4 (70)	3-3/4 (95)	4-1/2 (114)	3-1/2 (89)	5 (127)	6 (152)	4-3/4 (121)	5-1/2 (140)
Minimum edge distance	c_{min}	in. (mm)	3 (76)	2-1/4 (57)	4 (102)	5-1/4 (133)	4 (102)	4-1/4 (108)	5-1/2 (140)	4-1/4 (108)	5 (127)	4-1/2 (114)
Minimum spacing distance	s_{min}	in. (mm)	5-1/4 (133)	3-3/4 (95)	6 (152)	7-1/4 (184)	5 (127)	7-1/8 (181)	10-1/8 (257)	4-1/4 (108)	9 (229)	6 (152)
Critical edge distance	c_{ac}	in. (mm)	5 (127)	6-1/2 (165)	8 (203)	8-1/2 (216)	8 (203)	8 (203)	6 (152)	10 (254)	5 (127)	12 (305)
Installation torque (Normal-weight concrete)	T_{inst}	ft.-lbf. (N-m)	20 (27)		40 (54)		60 (81)			110 (149)		
Installation torque (Grout Filled CMU)	T_{inst}	ft.-lbf. (N-m)	20 (27)		40 (54)		50 (68)			80 (108)		
Torque wrench/socket size	-	in.	9/16		3/4		15/16			1-1/8		
Nut height	-	in.	21/64		7/16		35/64			41/64		

For SI: 1 inch = 25.4 mm, 1 ft-lbf = 1.356 N-m.

1. The listed minimum overall anchor length is based on anchor sizes available at the time of publication compared with the requirements for the minimum nominal embedment depth and fixture attachment.

ASD PERFORMANCE DATA

Ultimate Load Capacities for Power-Stud HD5 in Normal-Weight Concrete^{1,2}

Nominal Anchor Diameter (in.)	Minimum Embedment Depth (in.)	Minimum Concrete Compressive Strength - f'c (psi)									
		2,500 psi		3,000 psi		4,000 psi		6,000 psi		8,000 psi	
		Tension (lbs)	Shear (lbs)	Tension (lbs)	Shear (lbs)	Tension (lbs)	Shear (lbs)	Tension (lbs)	Shear (lbs)	Tension (lbs)	Shear (lbs)
3/8	1-3/4	2,470	3,925	2,710	3,925	3,130	3,925	3,220	3,925	3,715	3,925
3/8	2-3/8	3,620	3,925	3,965	3,925	4,580	3,925	5,470	3,925	6,320	3,925
1/2	2	2,690	4,195	2,950	4,195	3,405	4,195	4,170	4,195	4,815	4,195
1/2	2-1/2	4,140	4,195	4,540	4,195	5,240	4,195	6,415	4,195	7,410	4,195
1/2	3-3/4	8,580	4,195	9,400	4,195	10,300	4,195	10,300	4,195	10,300	4,195
5/8	2-1/2	4,115	6,815	4,505	6,815	5,200	6,815	6,370	6,815	7,355	6,815
5/8	3-3/8	7,305	6,815	8,000	6,815	9,240	6,815	11,315	6,815	13,065	6,815
5/8	4-5/8	11,715	6,815	12,830	6,815	14,815	6,815	16,400	6,815	16,400	6,815
3/4	3-3/8	7,080	11,570	7,750	11,570	8,955	11,570	12,125	11,570	14,000	11,570
3/4	5	16,965	11,570	18,580	11,570	21,330	11,570	21,330	11,570	21,330	11,570

1. Tabulated load values are applicable to single anchors installed in uncracked concrete with no edge or spacing considerations. Concrete compressive strength must be at the specified minimum at the time of installation.
2. Ultimate load capacities must be reduced by a minimum safety factor of 4.0 or greater to determine allowable working load.



Allowable Load Capacities for Power-Stud HD5 in Normal-Weight Concrete¹

Nominal Anchor Diameter (in.)	Minimum Embedment Depth (in.)	Minimum Concrete Compressive Strength - f'c (psi)									
		2,500 psi		3,000 psi		4,000 psi		6,000 psi		8,000 psi	
		Tension (lbs)	Shear (lbs)	Tension (lbs)	Shear (lbs)	Tension (lbs)	Shear (lbs)	Tension (lbs)	Shear (lbs)	Tension (lbs)	Shear (lbs)
3/8	1-3/4	620	980	680	980	785	980	805	980	930	980
3/8	2-3/8	905	980	990	980	1,145	980	1,370	980	1,580	980
1/2	2	675	1,050	740	1,050	850	1,050	1,045	1,050	1,205	1,050
1/2	2-1/2	1,035	1,050	1,135	1,050	1,310	1,050	1,605	1,050	1,855	1,050
1/2	3-3/4	2,145	1,050	2,350	1,050	2,575	1,050	2,575	1,050	2,575	1,050
5/8	2-1/2	1,030	1,705	1,125	1,705	1,300	1,705	1,595	1,705	1,840	1,705
5/8	3-3/8	1,825	1,705	2,000	1,705	2,310	1,705	2,830	1,705	3,265	1,705
5/8	4-5/8	2,930	1,705	3,210	1,705	3,705	1,705	4,100	1,705	4,100	1,705
3/4	3-3/8	1,770	2,895	1,940	2,895	2,240	2,895	3,030	2,895	3,500	2,895
3/4	5	4,240	2,895	4,645	2,895	5,335	2,895	5,335	2,895	5,335	2,895

1. Allowable load capacities listed are calculated using and applied safety factor of 4.0.
2. Allowable load capacities are multiplied by reduction factors when anchor spacing or edge distances are less than critical distances.

ALLOWABLE STRESS DESIGN (ASD) DESIGN CRITERIA

Spacing Distance and Edge Distance Tension (F_{ns}, F_{nc}) Adjustment Factors for Normal-Weight Concrete

Spacing Distance - Tension (F _{ns})											
Diameter, d (in)	3/8	3/8	1/2	1/2	1/2	5/8	5/8	5/8	3/4	3/4	
Minimum Embedment, h _v (in)	1-3/4	2-3/8	2	2-1/2	3-3/4	2-3/8	3-3/8	4-5/8	3-3/8	5	
Min. Slab Thickness, h _{min} (in)	3-1/4	4	4	5	6	5	6	7	6	10	
Minimum Spacing, s _{min} (in)	5-1/4	3-3/4	6	7-1/4	5	7-1/8	10-1/8	4-1/4	9	6	
Critical Spacing, S _{cr} (in)	5-1/4	7-1/8	6	7-1/2	11-1/4	7-1/8	10-1/8	13-7/8	10-1/8	15	
Spacing Distance (inches)	3-3/4	-	0.80	-	-	-	-	-	-	-	
	4	-	0.82	-	-	-	-	-	-	-	
	4-1/4	-	0.83	-	-	-	-	0.69	-	-	
	4-1/2	-	0.85	-	-	-	-	0.70	-	-	
	5	-	0.88	-	-	0.75	-	0.71	-	-	
	5-1/2	1.00	0.91	-	-	0.77	-	0.73	-	-	
	6	1.00	0.93	1.00	-	0.79	-	0.74	-	0.74	
	6-1/2	1.00	0.96	1.00	-	0.81	-	0.76	-	0.75	
	7	1.00	0.99	1.00	-	0.83	-	0.78	-	0.77	
	7-1/4	1.00	1.00	1.00	0.99	0.84	-	0.78	-	0.78	
	7-1/2	1.00	1.00	1.00	1.00	0.85	1.00	-	0.79	-	0.78
	8	1.00	1.00	1.00	1.00	0.87	1.00	-	0.81	-	0.80
	8-1/2	1.00	1.00	1.00	1.00	0.89	1.00	-	0.83	-	0.81
	9	1.00	1.00	1.00	1.00	0.91	1.00	-	0.84	0.94	0.83
	9-1/2	1.00	1.00	1.00	1.00	0.93	1.00	-	0.86	0.97	0.84
	10	1.00	1.00	1.00	1.00	0.95	1.00	-	0.87	0.99	0.86
	10-1/2	1.00	1.00	1.00	1.00	0.97	1.00	1.00	0.89	1.00	0.87
	11	1.00	1.00	1.00	1.00	0.99	1.00	1.00	0.91	1.00	0.88
11-1/2	1.00	1.00	1.00	1.00	1.00	1.00	1.00	0.92	1.00	0.90	
12	1.00	1.00	1.00	1.00	1.00	1.00	1.00	0.94	1.00	0.91	
12-1/2	1.00	1.00	1.00	1.00	1.00	1.00	1.00	0.96	1.00	0.93	
13	1.00	1.00	1.00	1.00	1.00	1.00	1.00	0.97	1.00	0.94	
13-1/2	1.00	1.00	1.00	1.00	1.00	1.00	1.00	0.99	1.00	0.96	
14	1.00	1.00	1.00	1.00	1.00	1.00	1.00	1.00	1.00	0.97	
14-1/2	1.00	1.00	1.00	1.00	1.00	1.00	1.00	1.00	1.00	0.99	
15	1.00	1.00	1.00	1.00	1.00	1.00	1.00	1.00	1.00	1.00	

Edge Distance - Tension (F _{nc})											
Diameter, d (in)	3/8	3/8	1/2	1/2	1/2	5/8	5/8	5/8	3/4	3/4	
Minimum Embedment, h _v (in)	1-3/4	2-3/8	2	2-1/2	3-3/4	2-3/8	3-3/8	4-5/8	3-3/8	5	
Min. Slab Thickness, h _{min} (in)	3-1/4	4	4	5	6	5	6	7	6	10	
Minimum Edge Distance, c _{min} (in)	3	2-1/4	4	5-1/4	4	4-1/4	5-1/2	4-1/4	5	4-1/2	
Critical Edge Distance, c _{cr} (in)	5	6-1/2	8	8-1/2	8	8	6	10	5	12	
Edge Distance (inches)	2-1/4	-	0.35	-	-	-	-	-	-	-	
	2-1/2	-	0.38	-	-	-	-	-	-	-	
	3	0.60	0.46	-	-	-	-	-	-	-	
	3-1/2	0.70	0.54	-	-	-	-	-	-	-	
	4	0.80	0.62	0.50	-	0.50	-	-	-	-	
	4-1/4	0.85	0.65	0.53	-	0.53	0.53	-	0.43	-	
	4-1/2	0.90	0.69	0.56	-	0.56	0.56	-	0.45	-	0.38
	5	1.00	0.77	0.63	-	0.63	0.63	-	0.50	1.00	0.42
	5-1/4	1.00	0.81	0.66	0.62	0.66	0.66	-	0.53	1.00	0.44
	5-1/2	1.00	0.85	0.69	0.65	0.69	0.69	0.92	0.55	1.00	0.46
	6	1.00	0.92	0.75	0.71	0.75	0.75	1.00	0.60	1.00	0.50
	6-1/2	1.00	1.00	0.81	0.76	0.81	0.81	1.00	0.65	1.00	0.54
	7	1.00	1.00	0.88	0.82	0.88	0.88	1.00	0.70	1.00	0.58
	7-1/2	1.00	1.00	0.94	0.88	0.94	0.94	1.00	0.75	1.00	0.63
	8	1.00	1.00	1.00	0.94	1.00	1.00	1.00	0.80	1.00	0.67
	8-1/2	1.00	1.00	1.00	1.00	1.00	1.00	1.00	0.85	1.00	0.71
	9	1.00	1.00	1.00	1.00	1.00	1.00	1.00	0.90	1.00	0.75
	9-1/2	1.00	1.00	1.00	1.00	1.00	1.00	1.00	0.95	1.00	0.79
10	1.00	1.00	1.00	1.00	1.00	1.00	1.00	1.00	1.00	0.83	
10-1/2	1.00	1.00	1.00	1.00	1.00	1.00	1.00	1.00	1.00	0.88	
11	1.00	1.00	1.00	1.00	1.00	1.00	1.00	1.00	1.00	0.92	
11-1/2	1.00	1.00	1.00	1.00	1.00	1.00	1.00	1.00	1.00	0.96	
12	1.00	1.00	1.00	1.00	1.00	1.00	1.00	1.00	1.00	1.00	

ALLOWABLE STRESS DESIGN (ASD) DESIGN CRITERIA

Spacing Distance Shear (Fvs) Adjustment Factors for Normal-Weight Concrete

Spacing Distance - Shear (Fvs)											
Diameter, d (in)	3/8	3/8	1/2	1/2	1/2	5/8	5/8	5/8	3/4	3/4	
Minimum Embedment, h_v (in)	1-3/4	2-3/8	2	2-1/2	3-3/4	2-3/8	3-3/8	4-5/8	3-3/8	5	
Min. Slab Thickness, h_{min} (in)	3-1/4	4	4	5	6	5	6	7	6	10	
Minimum Spacing, s_{min} (in)	5-1/4	3-3/4	6	7-1/4	5	7-1/8	11	4-1/4	9	6	
Critical Spacing, S_c (in)	5-1/4	7-1/8	6	7-1/2	11-1/4	7-1/8	11	13-7/8	10-1/8	15	
Spacing Distance (inches)	3-3/4	-	0.87	-	-	-	-	-	-	-	
	4	-	0.88	-	-	-	-	-	-	-	
	4-1/4	-	0.89	-	-	-	-	0.78	-	-	
	4-1/2	-	0.90	-	-	-	-	0.79	-	-	
	5	-	0.92	-	-	0.82	-	0.80	-	-	
	5-1/2	1.00	0.94	-	-	0.84	-	0.81	-	-	
	6	1.00	0.96	1.00	-	0.85	-	0.82	-	0.82	
	6-1/2	1.00	0.98	1.00	-	0.87	-	0.83	-	0.83	
	7	1.00	1.00	1.00	-	0.88	-	0.84	-	0.84	
	7-1/2	1.00	1.00	1.00	1.00	0.89	1.00	-	0.85	-	0.85
	8	1.00	1.00	1.00	1.00	0.91	1.00	-	0.87	-	0.86
	8-1/2	1.00	1.00	1.00	1.00	0.92	1.00	-	0.88	-	0.87
	9	1.00	1.00	1.00	1.00	0.94	1.00	-	0.89	0.96	0.88
	9-1/2	1.00	1.00	1.00	1.00	0.95	1.00	-	0.90	0.98	0.89
	10	1.00	1.00	1.00	1.00	0.96	1.00	-	0.91	1.00	0.90
	10-1/2	1.00	1.00	1.00	1.00	0.98	1.00	-	0.92	1.00	0.91
	11	1.00	1.00	1.00	1.00	0.99	1.00	1.00	0.93	1.00	0.92
	11-1/2	1.00	1.00	1.00	1.00	1.00	1.00	1.00	0.95	1.00	0.93
12	1.00	1.00	1.00	1.00	1.00	1.00	1.00	0.96	1.00	0.94	
12-1/2	1.00	1.00	1.00	1.00	1.00	1.00	1.00	0.97	1.00	0.95	
13	1.00	1.00	1.00	1.00	1.00	1.00	1.00	0.98	1.00	0.96	
13-1/2	1.00	1.00	1.00	1.00	1.00	1.00	1.00	0.99	1.00	0.97	
14	1.00	1.00	1.00	1.00	1.00	1.00	1.00	1.00	1.00	0.98	
14-1/2	1.00	1.00	1.00	1.00	1.00	1.00	1.00	1.00	1.00	0.99	
15	1.00	1.00	1.00	1.00	1.00	1.00	1.00	1.00	1.00	1.00	

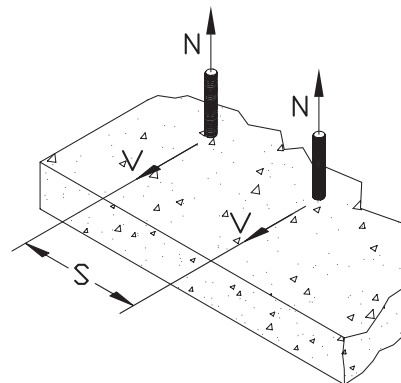

ALLOWABLE STRESS DESIGN (ASD) DESIGN CRITERIA

Edge Distance Shear (Fvc) Adjustment Factors for Normal-Weight Concrete

MECHANICAL ANCHORS

Edge Distance - Shear (Fvc)										
Diameter, d (in)	3/8	3/8	1/2	1/2	1/2	5/8	5/8	5/8	3/4	3/4
Minimum Embedment, h _v (in)	1-3/4	2-3/8	2	2-1/2	3-3/4	2-3/8	3-3/8	4-5/8	3-3/8	5
Min. Slab Thickness, h _{min} (in)	3-1/4	4	4	5	6	5	6	7	6	10
Minimum Edge Distance, c _{min} (in)	5	6-1/2	6	8-1/2	8	7-1/8	6	10	5	12
Critical Edge Distance, C _{ac} (in)	5-1/4	7-1/8	6	8-1/2	11-1/4	7-1/8	10-1/8	13-7/8	10-1/8	15
Edge Distance (inches)	5	0.95	-	-	-	-	-	-	0.49	-
	5-1/2	1.00	-	-	-	-	-	-	0.54	-
	6	1.00	-	1.00	-	-	-	0.59	-	0.59
	6-1/2	1.00	0.91	1.00	-	-	-	0.64	-	0.64
	7	1.00	0.98	1.00	-	-	-	0.69	-	0.69
	7-1/2	1.00	1.00	1.00	-	-	1.00	0.74	-	0.74
	8	1.00	1.00	1.00	-	0.71	1.00	0.79	-	0.79
	8-1/2	1.00	1.00	1.00	1.00	0.76	1.00	0.84	-	0.84
	9	1.00	1.00	1.00	1.00	0.80	1.00	0.89	-	0.89
	9-1/2	1.00	1.00	1.00	1.00	0.84	1.00	0.94	-	0.94
	10	1.00	1.00	1.00	1.00	0.89	1.00	0.99	0.72	0.99
	10-1/2	1.00	1.00	1.00	1.00	0.93	1.00	1.00	0.76	1.00
	11	1.00	1.00	1.00	1.00	0.98	1.00	1.00	0.79	1.00
	11-1/4	1.00	1.00	1.00	1.00	1.00	1.00	1.00	0.81	1.00
	11-1/2	1.00	1.00	1.00	1.00	1.00	1.00	1.00	0.83	1.00
	12	1.00	1.00	1.00	1.00	1.00	1.00	1.00	0.86	1.00
	12-1/2	1.00	1.00	1.00	1.00	1.00	1.00	1.00	0.90	1.00
	13	1.00	1.00	1.00	1.00	1.00	1.00	1.00	0.94	1.00
13-1/2	1.00	1.00	1.00	1.00	1.00	1.00	1.00	0.97	1.00	
14	1.00	1.00	1.00	1.00	1.00	1.00	1.00	1.00	1.00	
14-1/2	1.00	1.00	1.00	1.00	1.00	1.00	1.00	1.00	1.00	
15	1.00	1.00	1.00	1.00	1.00	1.00	1.00	1.00	1.00	

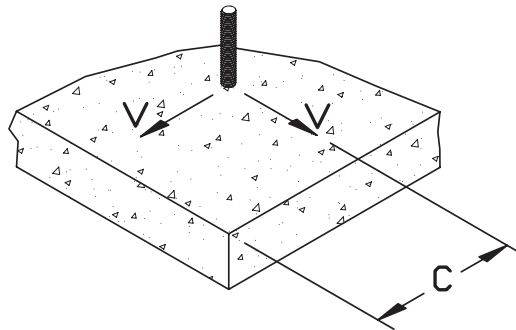

MASONRY PERFORMANCE DATA
Ultimate and Allowable Load Capacities for Power-Stud HD5 in Grout -Filled Concrete Masonry^{1,2,3}

Anchor Diameter d in.	Minimum Embed. h _v in. (mm)	Minimum Edge Distance in. (mm)	Minimum End Distance in. (mm)	Ultimate Loads		Allowable Loads	
				Tension lbs. (kN)	Shear lbs. (kN)	Tension lbs. (kN)	Shear lbs. (kN)
3/8	1-1/2 (38.1)	4 (102)	4 (102)	1,185 (5.3)	1,340 (6.0)	235 (1.0)	270 (1.2)
1/2	2 (50.8)	4 (102)	4 (102)	1,670 (7.4)	2,110 (9.4)	335 (1.5)	420 (1.9)
		12 (305)	12 (305)	1,860 (8.3)	2,560 (11.4)	370 (1.6)	510 (2.3)
5/8	2-3/8 (60.3)	4 (102)	4 (102)	2,155 (9.6)		430 (1.9)	
		12 (305)	12 (305)	2,850 (12.7)	5,225 (23.2)	570 (2.5)	1,045 (4.6)
3/4	3-3/8 (85.7)	12 (305)	12 (305)	5,660 (25.2)	8,115 (36.1)	1,130 (5.0)	1,625 (7.2)
		20 (508)	20 (508)		9,360 (41.6)		1,870 (8.3)

1. Tabulated load values are for anchors installed in minimum 6-inch wide, Grade N, Type II, light weight concrete masonry units conforming to ASTM C 90 that have reached the minimum designated ultimate compressive strength at the time of installation ($f'm \geq 1,500$ psi).

2. Allowable load capacities listed are calculated using an applied safety factor of 5.0. Consideration of safety factors of 10 or higher may be necessary depending on the application, such as life safety or overhead.

3. The tabulated values are for anchors installed at a minimum of 16 anchor diameters on center for 100 percent capacity. Spacing distances may be reduced to 8 anchor diameters on center provided the capacities are reduced by 50 percent. Linear interpolation may be used for intermediate spacing. Anchors with 3/4-inch diameter are limited to one anchor per cell.

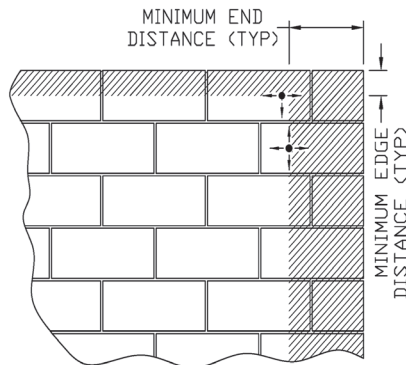

ORDERING INFORMATION

Power-Stud™ HD5 (Carbon Steel Body and Stainless Steel Expansion Clip)

Cat. No.	Anchor Size	Thread Length	Box Qty.	Carton Qty.	Wt/100 (lbs.)
7713HD5	3/8" x 3"	1-1/2"	50	300	10
7715HD5	3/8" x 3-3/4"	2-3/8"	50	300	13
7716HD5	3/8" x 5"	3-1/2"	50	300	15
7717HD5	3/8" x 7"	5-1/2"	50	200	21
7720HD5	1/2" x 2-3/4"	1"	50	200	21
7722HD5	1/2" x 3-3/4"	2"	50	200	19
7723HD5	1/2" x 4-1/2"	2-3/4"	50	200	23
7724HD5	1/2" x 5-1/2"	3-3/4"	50	200	27
7726HD5	1/2" x 7"	5-1/4"	50	150	30
7730HD5	5/8" x 3-1/2"	1-1/2"	25	100	44
7733HD5	5/8" x 5"	3"	25	100	43
7734HD5	5/8" x 6"	4"	25	100	47
7738HD5	5/8" x 8-1/2"	6-1/2"	25	75	60
7741HD5	3/4" x 4-3/4"	2-1/4"	20	60	68
7742HD5	3/4" x 5-1/2"	3"	20	60	76
7746HD5	3/4" x 7"	4-1/2"	20	60	92
7748HD5	3/4" x 8-1/2"	6"	10	40	107



MECHANICAL ANCHORS

The published size includes the diameter and the overall length of the anchor.
All anchors are packaged with nuts and washers.

Installation Accessories

Cat. No.	Description	Box Qty
08466	Adjustable torque wrench with 1/2" square drive (25 to 250 ft.-lbs.)	1
08280	Hand pump / dust blower	1

